



LIGHTING COLLECTION
CATALOGUE 2023





ITA Il catalogo di sistemi di illuminazione Paolo Castelli si compone di proposte indoor e outdoor dal carattere fortemente decorativo ed elegante, soluzioni ideali per spazi privati così come per progetti contract che esprimono il profondo know how dell'azienda e la continua ricerca nel campo delle finiture. Sintesi calibrate di creatività e tradizione artigiana, le lampade Paolo Castelli si distinguono per la ricchezza di dettagli e per le combinazioni materiche che ne animano i profili, rendendo unico e riconoscibile ogni prodotto. Versatili quanto eclettiche, i sistemi di illuminazione Paolo Castelli dialogano con l'ambiente regalando luminosità agli spazi e affascinando con il loro design.

EN Paolo Castelli lighting systems catalogue is composed of indoor and outdoor proposals with a strongly decorative and elegant character, ideal solutions for private spaces as well as for contract projects that express the company's profound know-how and continuous research in the field of finishes. A calibrated synthesis of creativity and artisan tradition, Paolo Castelli lamps stand out for the richness of their details and the material combinations that animate their profiles, making each product unique and recognisable. As versatile as they are eclectic, Paolo Castelli lighting systems dialogue with the surroundings, giving brightness to spaces and fascinating with their design.

Inspiration

Anodine Circle Light	7
Anodine Floor	9
Anodine Table & Mini	11
Anodine Wall	13
Origami Wall	15
Fanus Suspension	17
Fanus Floor	19
Fanus Table	21
Terminal	23
Manta Suspension	25
Manta Floor	27
Manta Table	29
Soreluna	31
My Lamp Round	33
My Lamp Rectangular	35
My Lamp Sphere	37
My Lamp Ceiling	39
My Lamp Wall	41
My Lamp Floor	43
My Lamp Table	45
Comet Floor & Table	47
Golden Disc Suspension	49
Golden Disc Wall	51
Golden Cloud Suspension	53
Golden Cloud Wall	55
Joy Suspension	57
Joy Wall	59

Kali Suspension	61
Kali Wall	63
Allure	65
Allure Side	67
Circle	69
Galaxy	71
Labilis Composition	73
Labilis Ring	75
Labilis Wall	77
Fair Light	79
Stellantis	81
Venus	83
Wave	85
Roulette	87
Colette & Hugo	89
Nettuno Table	91
Ambra Table	93

GREENKISS

Pablo Table	95
Hyperbole Table	97
Oscar Table	99
Kaala Table	101

Morandi Collection

Icone Luminose	103
Icone Luminose Table	105

Anodine Circle Light



Anodine Circle Light di giorno è una scultura che riflette le dinamiche della luce naturale. Una lampada dal forte rimando artistico che bene si adatta agli ambienti dalla ricercata personalità.

Si compone di tanti elementi luminosi in metallo con elegante finitura oro opaco satinato verniciata artigianalmente, legati tra di loro da un filo d'acciaio che fluttuano attorno alla lente centrale realizzata in metallo specchiato finitura oro lucido.

During the day, Anodine Circle Light is a sculpture that reflects the dynamics of natural light. A lamp with a strong artistic personality that suits spaces with a defined character.

It comprises metal elements with an elegant artisanal painting matt gold finish, bound together with a steel wire, that fluctuate around the central structure made of mirror polished metal with a polished gold finish.



Inspiration

Anodine Floor



Anodine Floor è una lampada da terra che trasforma la luce in una scultura attraverso il richiamo al concetto di "forma non forma" stilizzata della luce, arricchendo con una nota artistica d'eccellenza l'ambiente. È composta da 13 lunghi steli in ottone lucido ancorati ad una base metallica quadrata, alcuni vengono decorati da foglie in metallo realizzate asimmetricamente a mano da esperti artigiani e decorate con finitura oro opaco satinato. La base è in finitura oro opaco satinato. Perfetta in coppia per creare la giusta simmetria nello spazio. La preziosità della lavorazione artigianale rende ogni pezzo della collezione unico nel suo genere.

Anodine Floor is a free-standing lamp that transforms light into a sculpture evoking the concept of the "shape non-shape" light, which adds an artistic touch to the ambience. It comprises 13 shiny brass stems anchored to a square metal base finished "matt gold", some decorated with metal leaves, all asymmetrical and hand-made by expert artisans, with a matt gold satin finish. Perfect as a couple to create the right symmetry in the room. Thanks to hand-made manufacturing techniques, each piece of the collection is unique.



Inspiration

Anodine Table & Mini



Anodine Table è una graziosa lampada da tavolo. La preziosità della lavorazione artigianale rende ogni pezzo della collezione unico nel suo genere.

ANODINETABLE: È composta da 26 steli in ottone lucido ancorati ad una base metallica con finitura oro opaco satinato verniciata artigianalmente, che vengono decorati da foglie in metallo, realizzate asimmetricamente a mano da esperti artigiani e finite con finitura oro satinato.

ANODINE MINI: È composta da 3 steli in ottone lucido ancorati ad una base metallica con finitura oro opaco satinato, che vengono decorati da foglie in metallo realizzate asimmetricamente a mano da esperti artigiani con finitura oro opaco satinato verniciata artigianalmente.

Anodine table is a fair table lamp. Thanks to hand-made manufacturing techniques, each piece of the collection is unique.

ANODINE TABLE: It comprises 26 shiny brass stems anchored to a metal base with a matt gold satin artisanal painting finish, decorated with metal leaves, all asymmetrical and hand-made by expert artisans, with a matt gold finish.

ANODINE MINI: It comprises 3 shiny brass stems anchored to a metal base with a matt gold satin finish, decorated with metal leaves, all asymmetrical and hand-made by expert artisans, with a matt gold artisanal painting finish.

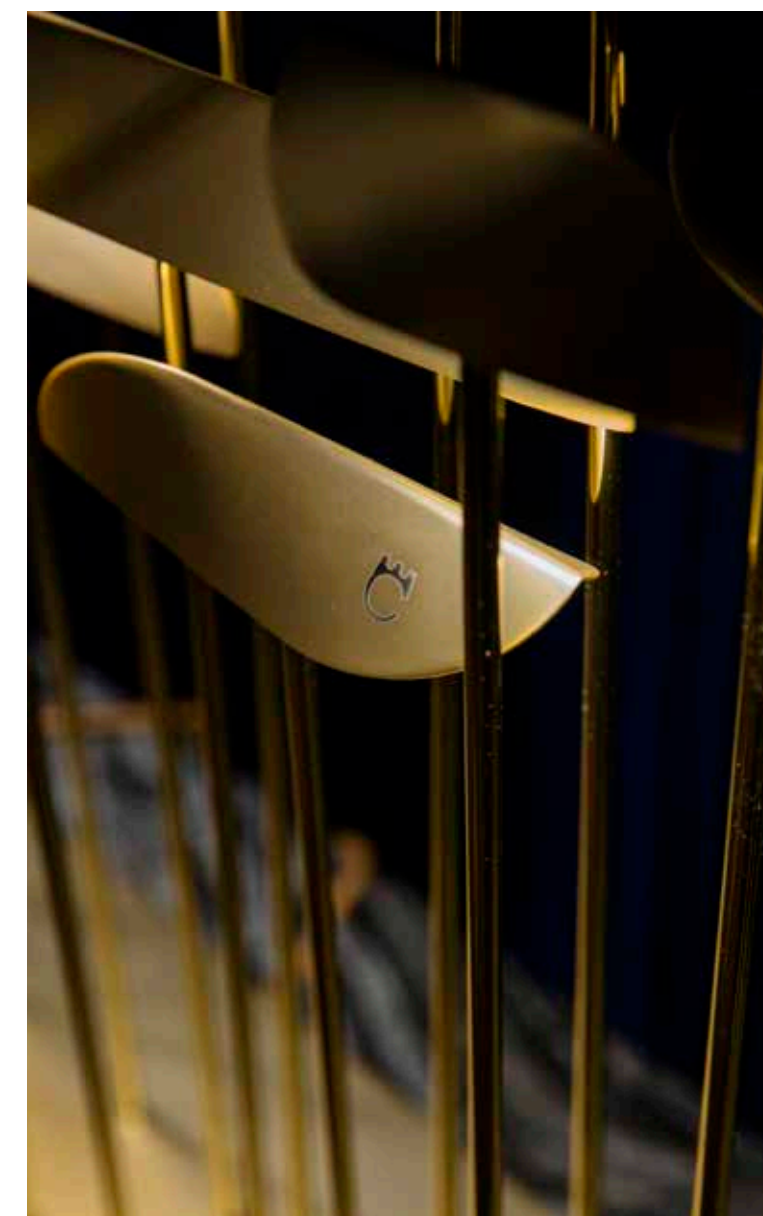

Inspiration

Anodine Wall



Anodine Wall è una graziosa lampada a parete che trasforma la luce in un dipinto attraverso il richiamo al concetto di "forma non forma" stilizzata della luce, arricchendo con una nota artistica d'eccellenza l'ambiente.

La composizione consta di 11 elementi, ognuno dei quali è a forma di foglia in metallo, realizzato asimmetricamente a mano da esperti artigiani con finitura oro satinato. Nel modulo fisso a 8 elementi, 3 sono dotati di Led da 2W ognuno. La composizione è completata da 3 elementi singoli, da disporre a piacere per creare infinite combinazioni. La preziosità della lavorazione artigianale rende ogni pezzo della collezione unico nel suo genere.

Anodine Wall is a delicate wall lamp that transforms light into a painting evoking the concept of "shape non-shape" of the light, which adds an artistic touch to the ambience.

It comprises 11 shiny metal leaves, all asymmetrical and hand-made by expert artisans, with a gold. In the fixed eight-element module, three leaves are lighted by 2W LED each. The composition is completed by 3 single elements, to be installed by choice in order to create endless combinations. Thanks to hand-made manufacturing techniques, each piece of the collection is unique.



Inspiration

Origami Wall



Una bellezza sottile, una luce piena e mai invadente che illumina l'ambiente evocando atmosfere lontane. La lampada a parete Origami, si contraddistingue per il tratto contemporaneo e longilineo delle sue singole componenti formate ognuna da due elementi: la struttura in doppia finitura, oro opaco satinato e nero opaco, viene attraversata da un'asta in ottone contenente la sorgente di luce a led. Combinati tra loro, i raggi formano un ventaglio di luce che anima lo spazio donando movimento alla parete. La particolarità del suo design, permette ad Origami di dare vita a molteplici composizioni grafiche, rivelando il suo carattere fortemente decorativo, anche a luci spente.

A subtle beauty, a full and never intrusive light that illuminates the room, evoking distant atmospheres. The Origami wall lamp is characterised by the contemporary and long-linear design of its individual components, each consisting of two elements: the structure in a double finish, satin matt gold and matt black, is crossed by a brass rod containing the led light source. Combined, the beams form a fan of light that animates the space, giving movement to the wall. The uniqueness of its design allows Origami to create multiple graphic compositions, revealing its highly decorative character, even when the lights are off.

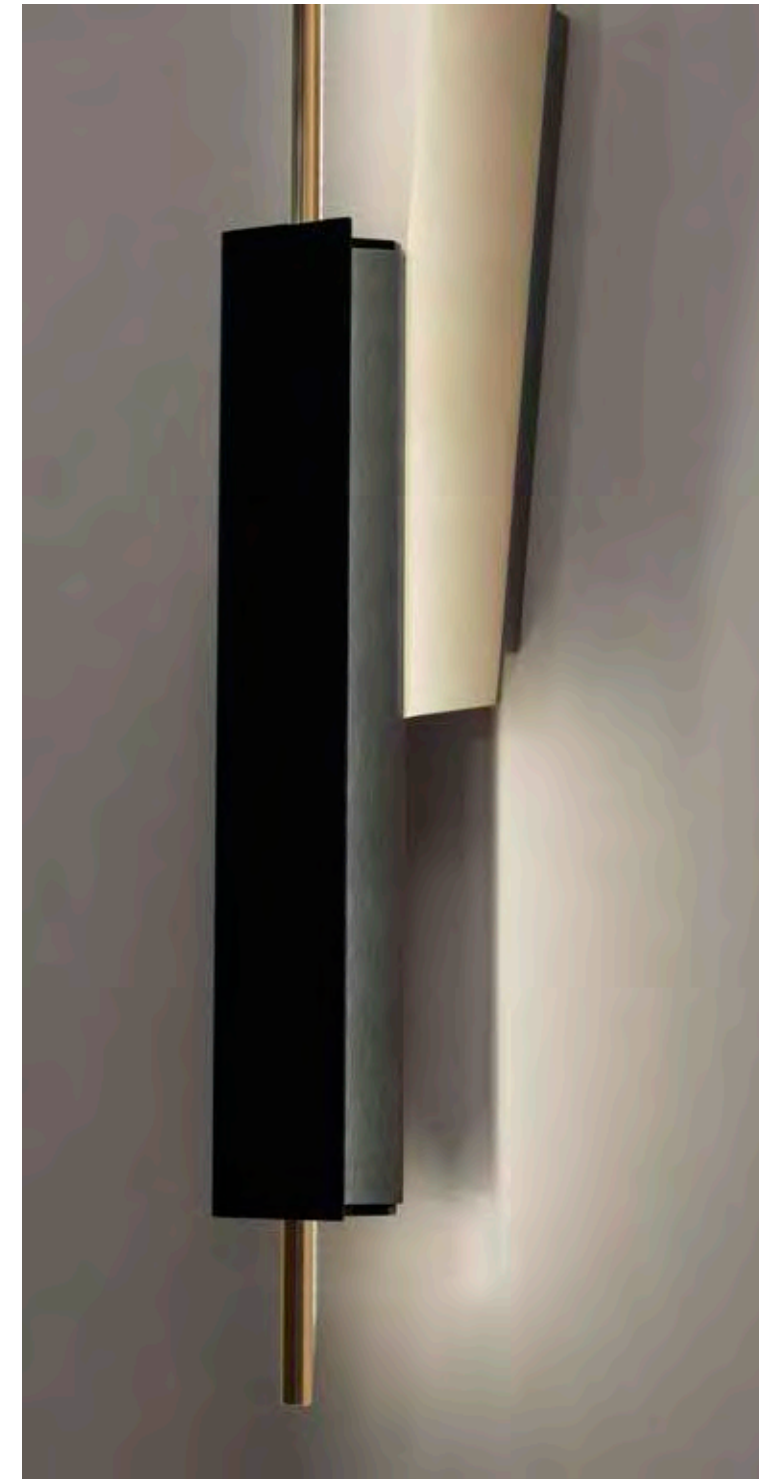

Inspiration

Fanus Suspension



Una lampada pensata per illuminare lo spazio e regalare l'intimità dell'ombra. Alimentata da una sorgente di luce a led, Fanus reinterpreta il concetto di lanterna, distinguendosi per il corpo centrale illuminante realizzato in vetro cannettato trasparente e per il paralume disponibile in tessuto o in vetro di Murano. Dettagli in cuoio naturale impreziosiscono l'intera figura, rendendo Fanus un progetto fortemente contemporaneo, disponibile a sospensione, da terra e nella versione da tavolo con cavo e batteria.

A lamp designed to illuminate space and provide the intimacy of shade. Powered by a led light source, Fanus reinterprets the concept of the lantern, distinguished by a central illuminating body made of transparent canned glass and a lampshade available in fabric or Murano glass. Natural cowhide leather details embellish the entire figure, making Fanus a highly contemporary design, available in a pendant, floor and table version with cable and battery.



Inspiration

Fanus Floor



Una lampada pensata per illuminare lo spazio e regalare l'intimità dell'ombra. Alimentata da una sorgente di luce a led, Fanus reinterpreta il concetto di lanterna, distinguendosi per il corpo centrale illuminante realizzato in vetro cannettato trasparente e per il paralume disponibile in tessuto o in vetro di Murano. Dettagli in cuoietto naturale impreziosiscono l'intera figura, rendendo Fanus un progetto fortemente contemporaneo, disponibile a sospensione, da terra e nella versione da tavolo con cavo e batteria

A lamp designed to illuminate space and provide the intimacy of shade. Powered by a led light source, Fanus reinterprets the concept of the lantern, distinguished by a central illuminating body made of transparent canned glass and a lampshade available in fabric or Murano glass.

Natural cuoietto leather details embellish the entire figure, making Fanus a highly contemporary design, available in a pendant, floor and table version with cable and battery.

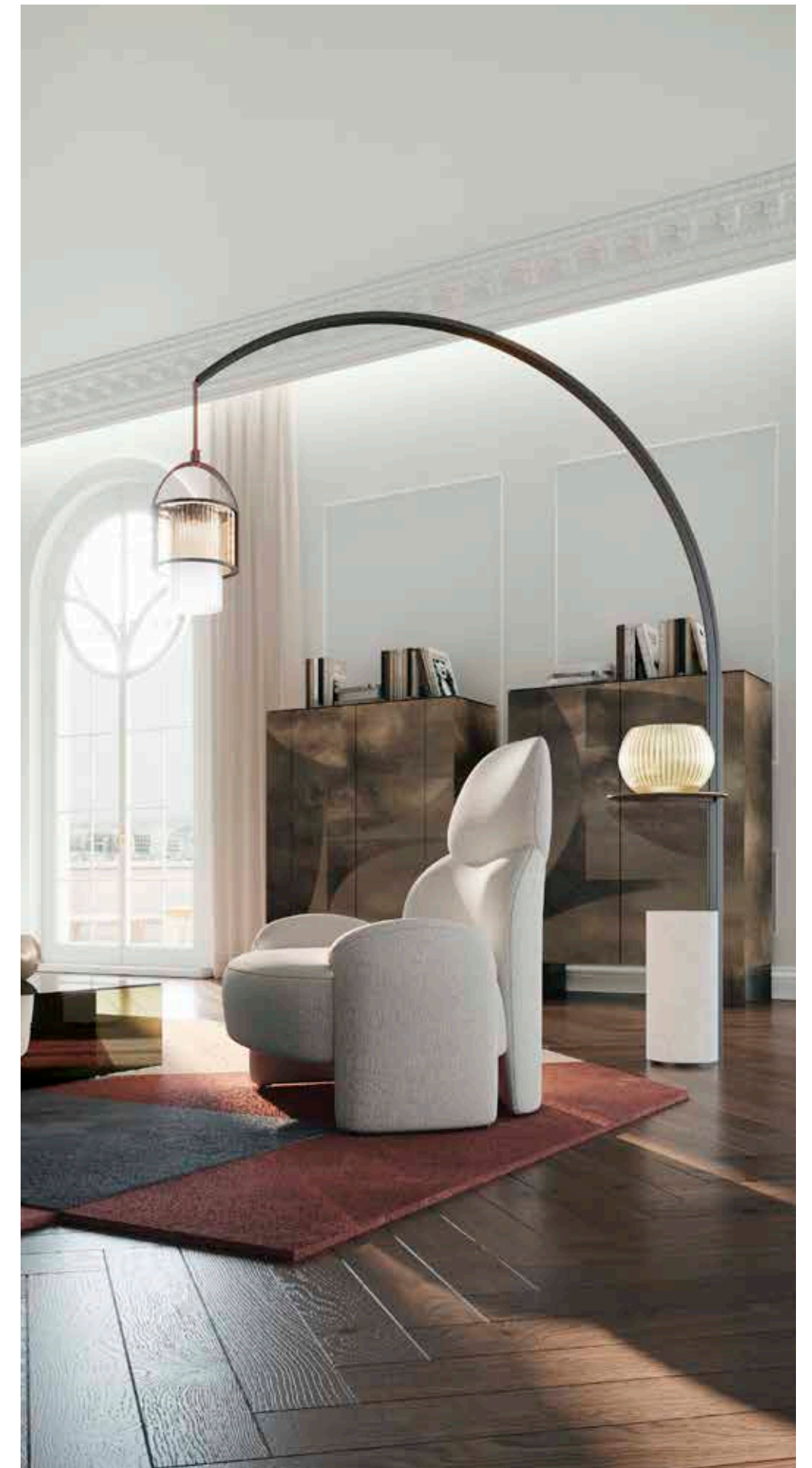

Inspiration

Fanus Table



Una lampada pensata per illuminare lo spazio e regalare l'intimità dell'ombra. Alimentata da una sorgente di luce a led, Fanus reinterpreta il concetto di lanterna, distinguendosi per il corpo centrale illuminante realizzato in vetro cannettato trasparente e per il paralume disponibile in tessuto o in vetro di Murano. Dettagli in cuoietto naturale impreziosiscono l'intera figura, rendendo Fanus un progetto fortemente contemporaneo, disponibile a sospensione, da terra e nella versione da tavolo con cavo e batteria.

A lamp designed to illuminate space and provide the intimacy of shade. Powered by a led light source, Fanus reinterprets the concept of the lantern, distinguished by a central illuminating body made of transparent canned glass and a lampshade available in fabric or Murano glass. Natural cuoietto leather details embellish the entire figure, making Fanus a highly contemporary design, available in a pendant, floor and table version with cable and battery.

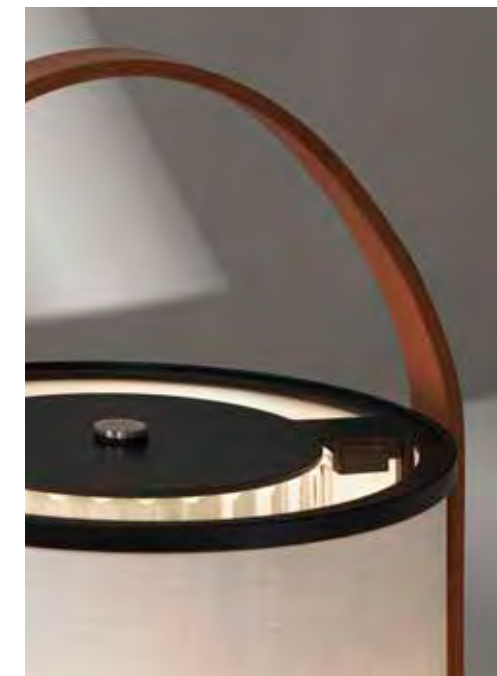

Inspiration

Terminal

Nuova lampada da esterno in versione sospesa e applique. Terminal ha una forma delicata e leggera che ricorda quella dei tradizionali isolatori. Il diffusore è composto da elementi sovrapposti in vetro borosilicato trasparente o in ceramica siciliana smaltata a mano nei colori bianco e azzurro. Al centro un corpo tubolare in acciaio traforato con finitura color champagne protegge la sorgente a LED IP67, resistente all'acqua e agli agenti esterni.

A new outdoor lamp in a suspended and applique version. Terminal lamp has a delicate and light shape reminding the one of the traditional insulators. The diffuser is made up of overlapping elements in transparent borosilicate glass or hand-glazed Sicilian ceramic. In the center, a tubular body in perforated steel with a champagne-colored finish protects the IP67 LED source, is resistant to water and external agents.



Manta Suspension



Manta è una scenografica lampada a sospensione che per la sua eterea leggerezza ricorda gli iconici Mobile di Alexander Calder. Il corpo illuminante con sorgente a LED incapsulata in una struttura cilindrica in ottone satinato è una foglia in vetro color ambra, forgiata a mano dai maestri vetrai di Murano. Ha una forma delicata e sinuosa e il lampadario sembra volare, grazie alle piccole foglie che volteggiano nell'aria, legate a sottilissimi cavi di sospensione.

Su richiesta ogni pendente viene fornito di una rosetta contenente il driver per il posizionamento a soffitto.

Manta is a scenographic suspension lamp whose ethereal lightness recalls the iconic Mobile sculpture by Alexander Calder. Amber coloured glass leave, hand-forged in Murano, encapsulated in a cylindrical satin brass structure which contains the LED light source. It has a delicate and sinuous shape and seems to be flying in the air, hanging from very thin electrified suspension cables.

On request any pendant can be provided with metal rosette holding local driver suitable for ceiling installation.



Inspiration

Manta Floor



Manta è una scenografica lampada a sospensione che per la sua eterea leggerezza ricorda gli iconici Mobile di Alexander Calder. Il corpo illuminante con sorgente a LED incapsulata in una struttura cilindrica in ottone satinato è una foglia in vetro color ambra, forgiata a mano dai maestri vetrai di Murano. Ha una forma delicata e sinuosa e il lampadario sembra volare, grazie alle piccole foglie che volteggiano nell'aria, legate a sottilissimi cavi di sospensione.

Su richiesta ogni pendente viene fornito di una rosetta contenente il driver per il posizionamento a soffitto.

Manta is a scenographic suspension lamp whose ethereal lightness recalls the iconic Mobile sculpture by Alexander Calder. Amber coloured glass leave, hand-forged in Murano, encapsulated in a cylindrical satin brass structure which contains the LED light source. It has a delicate and sinuous shape and seems to be flying in the air, hanging from very thin electrified suspension cables.

On request any pendant can be provided with metal rosette holding local driver suitable for ceiling installation.



Manta Table



Manta è una scenografica lampada a sospensione che per la sua eterea leggerezza ricorda gli iconici Mobile di Alexander Calder. Il corpo illuminante con sorgente a LED incapsulata in una struttura cilindrica in ottone satinato è una foglia in vetro color ambra, forgiata a mano dai maestri vetrai di Murano. Ha una forma delicata e sinuosa e il lampadario sembra volare, grazie alle piccole foglie che volteggiano nell'aria, legate a sottilissimi cavi di sospensione. Su richiesta ogni pendente viene fornito di una rosetta contenente il driver per il posizionamento a soffitto.

Manta is a scenographic suspension lamp whose ethereal lightness recalls the iconic Mobile sculpture by Alexander Calder. Amber coloured glass leave, hand-forged in Murano, encapsulated in a cylindrical satin brass structure which contains the LED light source. It has a delicate and sinuous shape and seems to be flying in the air, hanging from very thin electrified suspension cables. On request any pendant can be provided with metal rosette holding local driver suitable for ceiling installation.



Inspiration

Soreluna



Lampada ancorata a soffitto composta da un cavo tirante centrale e contrappeso a terra realizzato in metallo verniciato nero opaco. Il cavo tirante centrale monta tre lampade coniche realizzate in metallo, con finitura oro opaco ed emissione luminosa con piastrine led circolari. Il rosone a soffitto è sempre di forma conica, in metallo finitura oro opaco. Su richiesta disponibile anche il fissaggio a parete.

Lamp anchored to the ceiling consisting of a central tie-rod cable and ground counterweight made of metal - matt varnished black. The central pull cable mounts three conical lamps made of metal, with a matt gold finish and light emission with circular LED plates. The ceiling rose is always conical in shape, in metal with a matt gold finish. On request optional wall bracket.



Inspiration

My Lamp Round



My Lamp Round di diametro 50 e 100 cm, sono lampadari tondi che possono creare un effetto dinamico e di forte impatto se disposto in più pezzi. Ideale per salotti e sale da pranzo raffinati dove si vuole creare un ambiente sofisticato ma non convenzionale. È composto da un importante bouquet di tubi realizzati in vetro borosilicato veneziano posti ad altezze sfasate e raccolti in una fascia metallica curvata, trattata con particolare finitura a più strati oro opaco. Il telaio portante interno è realizzato in metallo nichelato. Contropiastra opalescente per diffondere la luce.

My Lamp Round with 50 and 100 cm diameter are round hanging lamps that bring a dynamic effect and have a great visual impact in arrangements with multiple pieces. Ideal in elegant lounges and dining rooms that want to create a sophisticated but unconventional ambience. It comprises a significant "bouquet" of venetian borosilicate glass tubes, hanging from different heights, bound together by a curved metal band with a unique finish matt gold. The internal supporting frame is made of nickel-plated metal. Opalescent counterplate to diffuse the light.

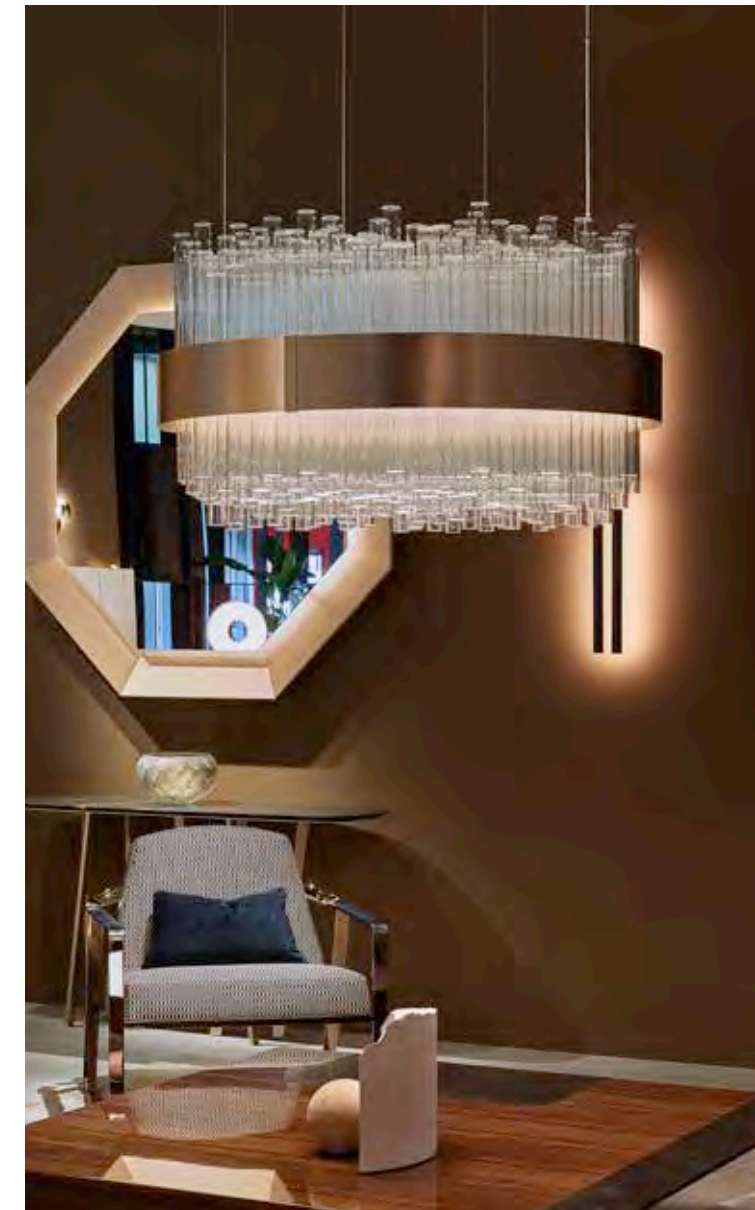

Inspiration

My Lamp Rectangular



My Lamp Rectangular e Square, sono lampadari che possono creare un effetto dinamico e di forte impatto se disposti in più pezzi. Ideale per salotti e sale da pranzo raffinati dove si vuole creare un ambiente sofisticato ma non convenzionale. È composto da un importante bouquet di tubi realizzati in vetro borosilicato veneziano posti ad altezze sfasate e raccolti in una fascia metallica curvata, trattata con particolare finitura a più strati oro opaco. Il telaio portante interno è realizzato in metallo nichelato. Contropiastra opalescente per diffondere la luce.

My Lamp Rectangular and Square are hanging lamps that bring a dynamic effect and have a great visual impact in arrangements with multiple pieces. Ideal in elegant lounges and dining rooms that want to create a sophisticated but unconventional ambience. It comprises a significant "bouquet" of venetian borosilicate glass tubes, hanging from different heights, bound together by a curved metal band with a unique finish matt gold. The internal supporting frame is made of nickel-plated metal. Opalescent counterplate to diffuse the light.

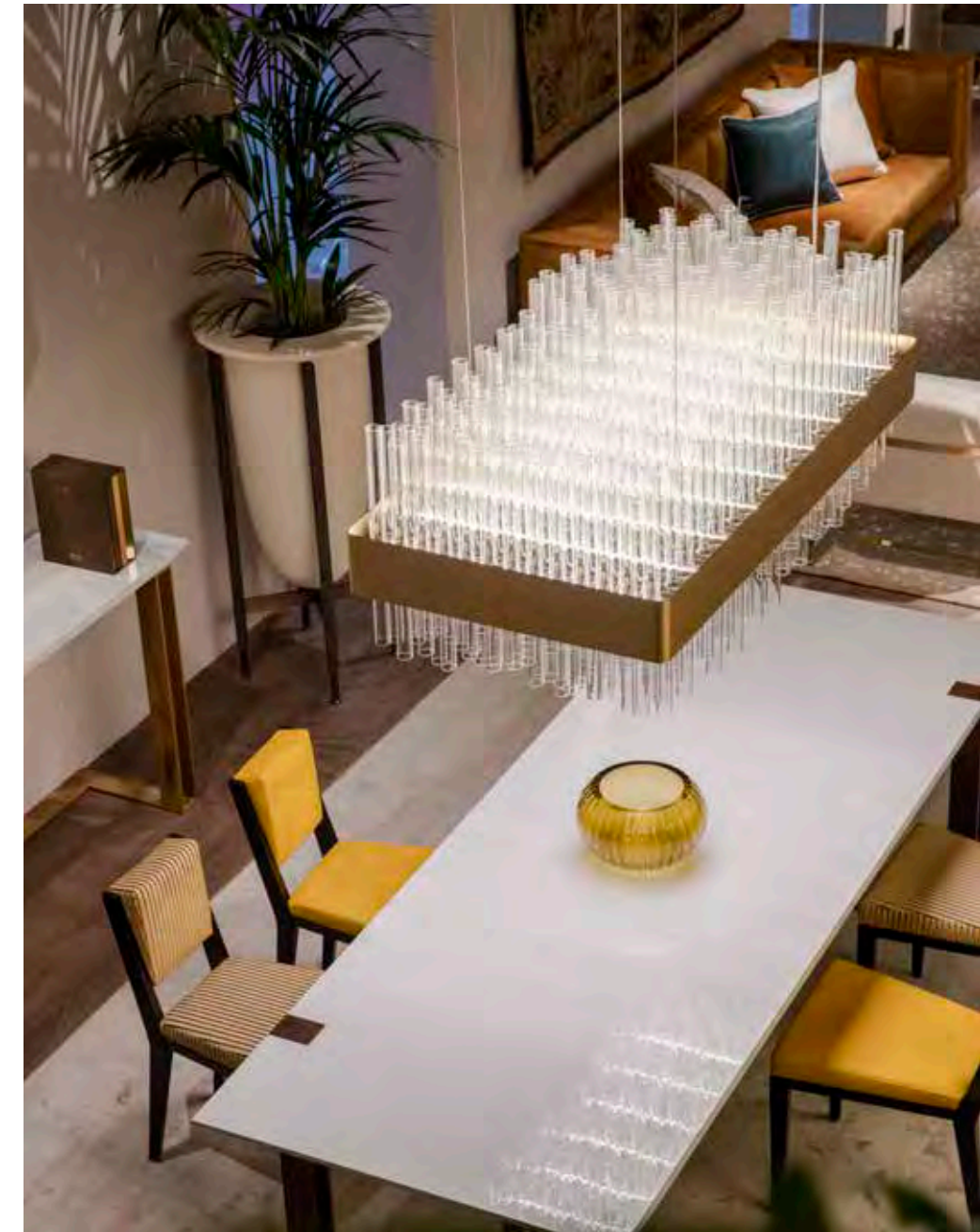

My Lamp Sphere



My Lamp Sphere è composto da un importante bouquet di tubi realizzati in vetro borosilicato veneziano posti ad altezze sfasate e raccolti in una fascia metallica curvata, trattata con particolare finitura a più strati oro opaco. Il telaio portante interno è realizzato in metallo nichelato.

My Lamp Sphere comprises a significant "bouquet" of venetian borosilicate glass tubes, hanging from different heights, bound together by a curved metal band with a unique finish matt gold. The internal supporting frame is made of nickel-plated metal.



Inspiration

My Lamp Ceiling



My lamp ceiling è una plafoniera circolare fortemente scenografica, che attraverso le diverse altezze dei vetri illuminati crea un decoro dinamico e raffinato. È composta da un importante bouquet di tubi realizzati in vetro borosilicato veneziano e raccolti in una fascia metallica curvata, trattata con particolare finitura oro opaco. Il telaio portante interno è realizzato in metallo nichelato. Disponibile in 2 misure.

My lamp ceiling is a round lamp with a great visual impact, which adds a dynamic and elegant touch thanks to the different heights of lit glass elements. It comprises a significant "bouquet" of venetian borosilicate glass tubes bound together by a curved metal band matt gold finished. The internal supporting structure has a nickel metal finish.

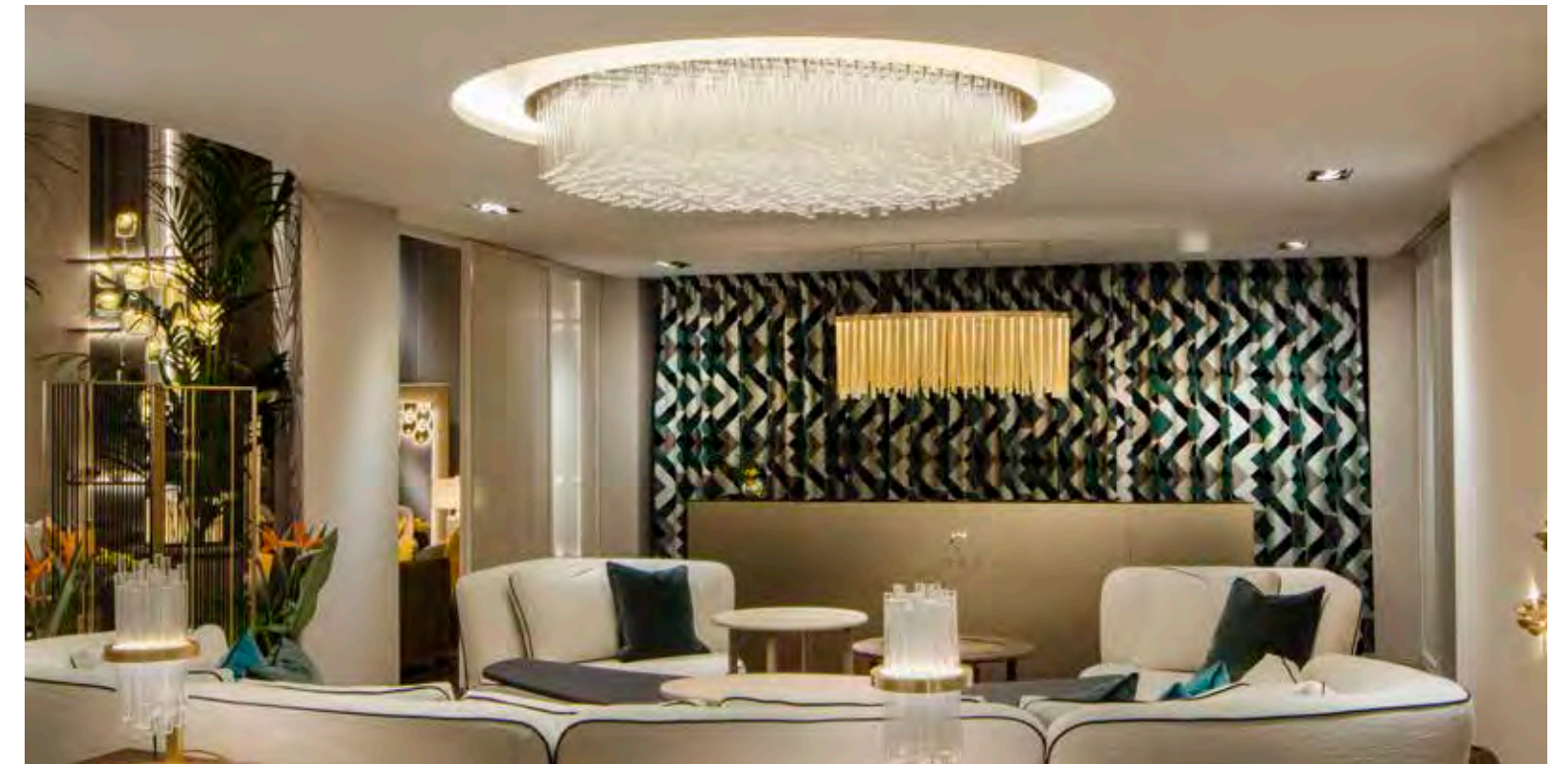

My Lamp Wall



My Lamp Wall è una raffinata ed elegante lampada a parete che completa la collezione My Lamp. Si compone di un raffinato bouquet di tubi realizzati in vetro borosilicato veneziano e raccolti in una fascia metallica con finitura oro opaco.

My Lamp Wall is a stylish and elegant wall lamp that completes the My Lamp collection. It comprises a significant "bouquet" of venetian borosilicate glass tubes bound together by a metal band with a unique finish matt gold.

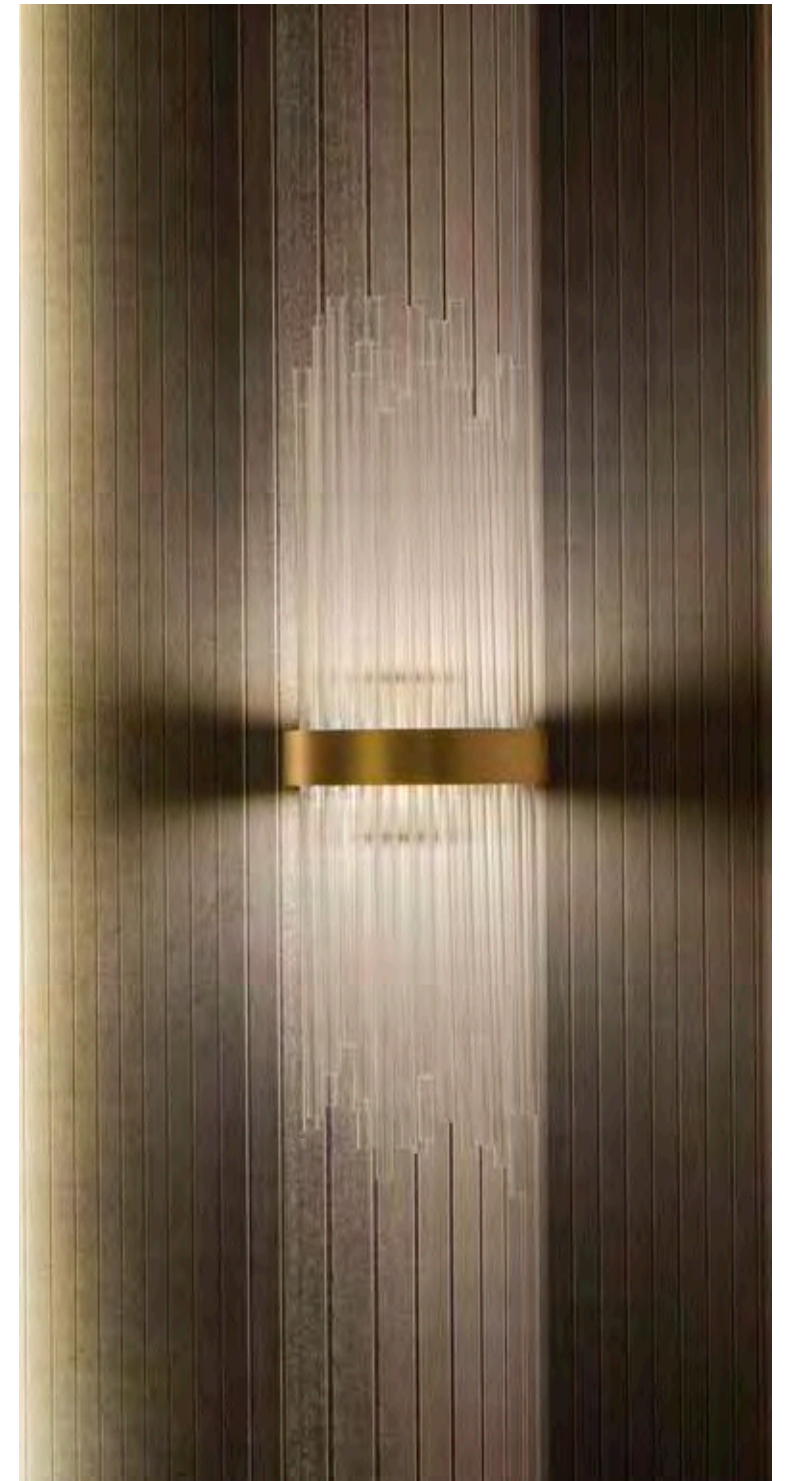

Inspiration

My Lamp Floor



My Lamp Floor è una lampada da terra, elegante nelle forme, che dona una luce ed un'atmosfera calda all'ambiente in cui viene inserito. Da solo o in coppia, per creare una perfetta simmetria, arricchisce e caratterizza ogni possibile situazione abitativa. È realizzato con una base e struttura in metallo, rifinita in finitura oro opaco e tubi cilindrici aperti realizzati in vetro borosilicato veneziano.

My Lamp Floor is a standing lamp, boasting an elegant shape that brings light and a warm atmosphere to any space. Single or in a pair, to create a perfect symmetry, enriches and adds character to any room. It features a metal base and a structure with matt gold finish and open cylindrical tubes made from venetian borosilicate glass.



My Lamp Table



My lamp table è una graziosa ed elegante lampada da tavolo, ideale per studi, salotti e zona notte, composta da una struttura metallica trattata in finitura oro opaco che regge un piccolo bouquet di tubi realizzati in vetro borosilicato veneziano.

My lamp table is a visually pleasing and elegant desk lamp, ideal for studios, lounges and bedrooms. It comprises a metal structure with a matt gold finish that supports a "bouquet" of tubes made from venetian borosilicate glass.



Inspiration

Comet Floor & Table



Lampade totemiche realizzate con basamento in noce Canaletto oliato o in legno metallizzato con finitura zinco acidato, impreziosito da un inserto in ottone satinato opaco. Paralume a forma di anello realizzato in tessuto naturale col. avorio.

Totemic lamps made with base in oiled Canaletto walnut or in metallized wood with acidetched zinc finish, embellished with an insert in matt satin brass. Ring-shaped lampshade made of natural fabric col. ivory.



Inspiration

Golden Disc Suspension



Il disco di luce è un simbolo antico, universale e fonte infinita di ispirazione. La sua geometria perfetta e leggera, unita alla foglia oro 24Kt, ne esalta la ricercata lavorazione artigianale. Golden Disc è una lampada a sospensione costituita da un elemento luminoso in vetro di Murano con un triplo passaggio di foglia d'oro, modellato a mano in stampo sagomato. Il vetro, che riflette la luce e la diffonde nell'ambiente, è incastonato in un disco di metallo finitura oro opaco satinato e sostenuto da un supporto metallico rivestito in pelle color sabbia. Ciascun elemento è fornito di un rosone in metallo finitura oro opaco e di un cavo elettrico di supporto della lunghezza massima di 2 m.

The disc of light is an ancient, universal symbol and never-ending source of inspiration. Its perfect, light geometry, combined with 24-carat gold leaf, enhances its sophisticated craftsmanship. Golden Disc is a suspension lamp created with hand-moulded lighting element made of Murano glass, coated with three layers of gold leaf. The glass, which reflects the light and radiates it around the room, is set in a matt gold-finish metal disc and sustained by a metal support upholstered in sand-coloured leather. Each element comes with a rose made of matt gold-finish metal and an electrical support cable with a maximum length of 2 metres.



Inspiration

Golden Disc Wall



Preziosa lampada a parete interamente realizzata a mano secondo le più antiche tradizioni muranesi. L'elemento, realizzato in vetro di Murano con un triplo passaggio di foglia d'oro 24Kt, è agganciato a un corpo metallico in finitura oro opaco che alloggia al suo interno la sorgente led e il proprio driver.

Precious wall lamp entirely handmade according to the most ancient Murano traditions. The element, made of Murano glass with a triple passage of 24Kt gold leaf, is hanged to a metal body in matt gold finish which hosts the LED source and its driver inside.

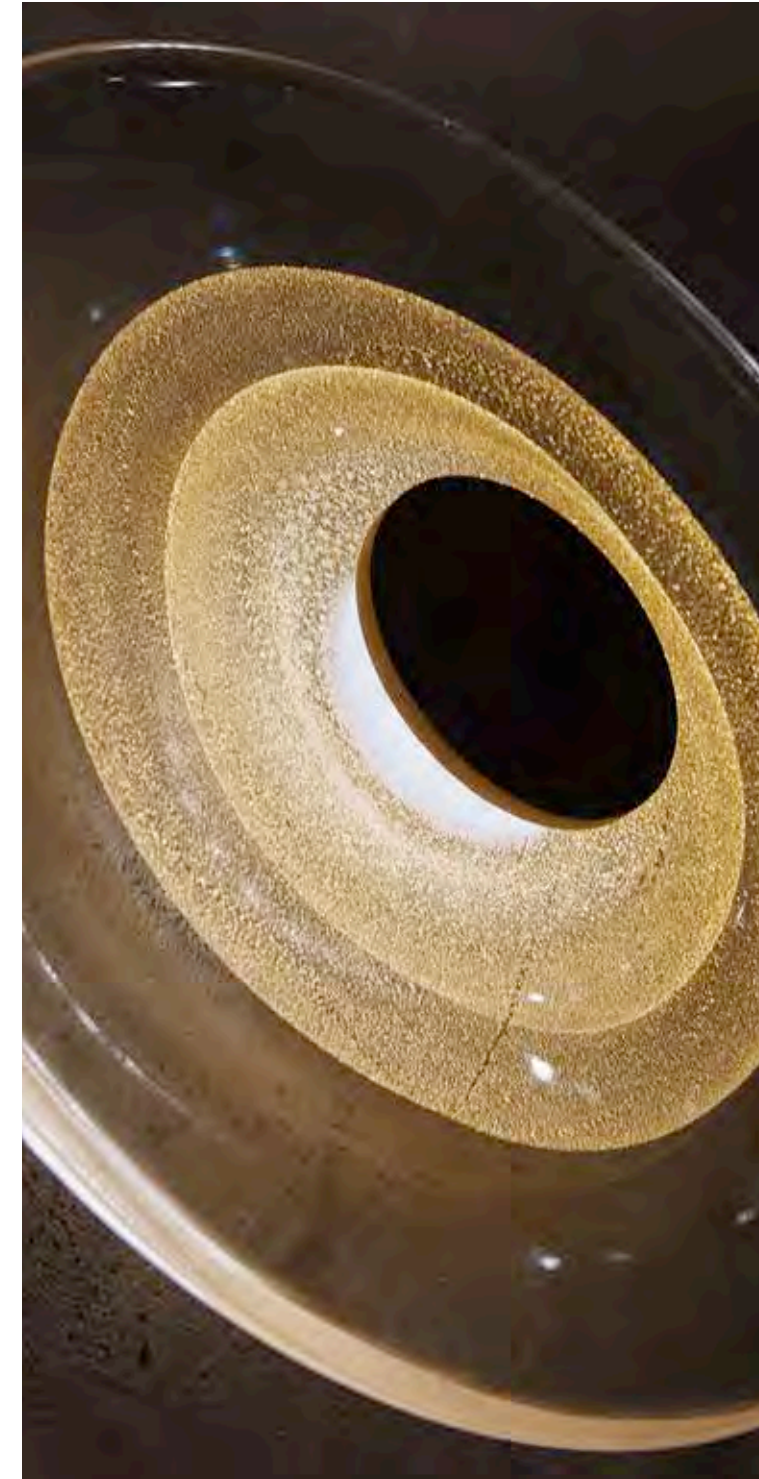

Inspiration

Golden Cloud Suspension



Prezioso lampadario interamente realizzato a mano secondo le più antiche tradizioni muranesi. Il corpo delle 22 "nuvole" (versione oval con 6 spot integrati) e 23 "nuvole" (versione round, con 5 spot integrati), disposte ad altezze sfalsate, è realizzato in vetro di murano con un triplo passaggio di foglia d'oro e viene modellato a mano in stampo sagomato.

La "nuvola" in vetro è agganciata a un corpo metallico in finitura oro satinato e alloggia al suo interno un moderno supporto a led. Il corpo metallico è infine ancorato su una piastra in acciaio, verniciata opaca in bianco RAL 9016, nero RAL 9005, oro. È disponibile in due versioni: Oval e Round.

A refined chandelier made entirely by hand following the most ancient Murano traditions. The body of the 22 "clouds" (Oval version, with 6 built-in spotlights) and 23 "clouds" (Round version, with 5 built-in spotlights), arranged at staggered heights, is made of Murano glass with a triple pass of gold leaf and is formed by hand in a shaped mould.

The glass "cloud" is attached to a metal body with a satin gold finish and houses a modern LED fitting. The metal body is anchored to a steel plate painted matt white RAL 9016, black RAL 9005, gold. Available in two versions: Oval and Round.

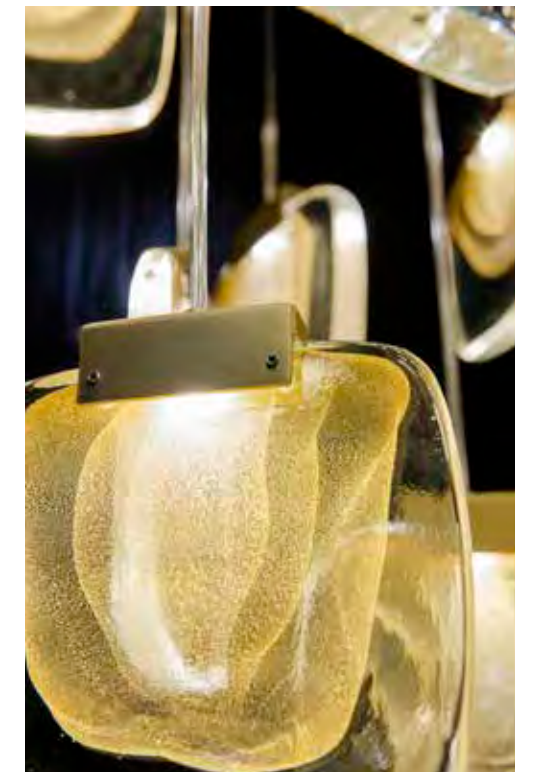

Inspiration

Golden Cloud Wall



Preziosa lampada a parete interamente realizzata a mano secondo le più antiche tradizioni muranesi. L'elemento, realizzato in vetro di Murano con un triplo passaggio di foglia d'oro 24Kt, è agganciato a un corpo metallico in finitura oro opaco che alloggia al suo interno la sorgente led e il proprio driver.

Precious wall lamp entirely handmade according to the most ancient Murano traditions. The element, made of Murano glass with a triple passage of 24Kt gold leaf, is hanged to a metal body in matt gold finish which hosts the LED source and its driver inside.

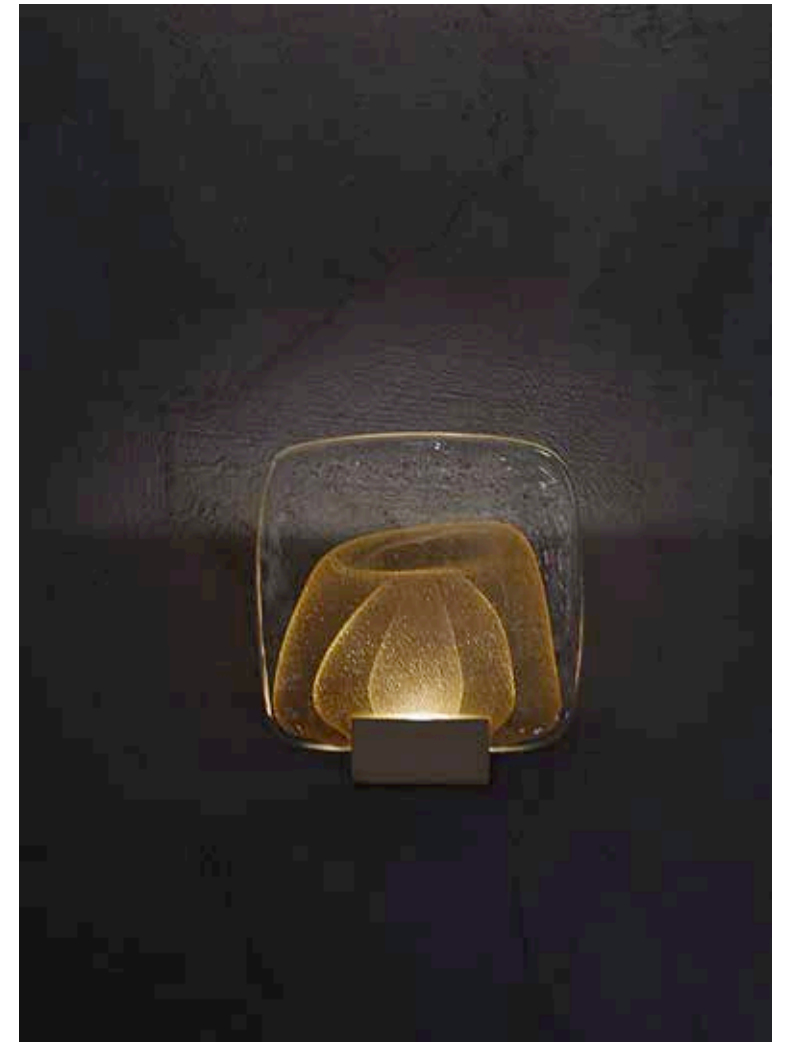

Inspiration

Joy Suspension



La composizione Joy nasce dal tema di dare corpo alla luce. La lampada è composta da tre anelli in ottone, ad altezza variabile, e sfere in vetro soffiato satinato bianco opaco (sfera grande) e rosso amaranth trasparente (sfera piccola) magicamente sospese all'interno della struttura metallica sottile. Un gioco di masse e di traiettorie circolari genera un disegno bilanciato di dinamiche gravitazionali. La luce emanata dalle sfere si diffonde sullo spazio circostante e irraggia il telaio. I riflessi dell'ottone contribuiscono a rendere l'atmosfera ancora più sofisticata e onirica.

Disponibile la versione a un anello e a tre anelli.

Joy composition was born from the idea of giving form to light. The lamp is composed of three brass rings, with variable height, and spheres in hand-blown white satin glass (big sphere) and Amaranth see-through, (small sphere) magically suspended within a thin metal structure. The play of circular masses and trajectories generates a balanced design of gravitational dynamics. The light from the sphere is diffused into the surrounding space, illuminating the frame. The reflections of the brass render the luminous field visible by its aura.

Available versions: one ring, three rings.

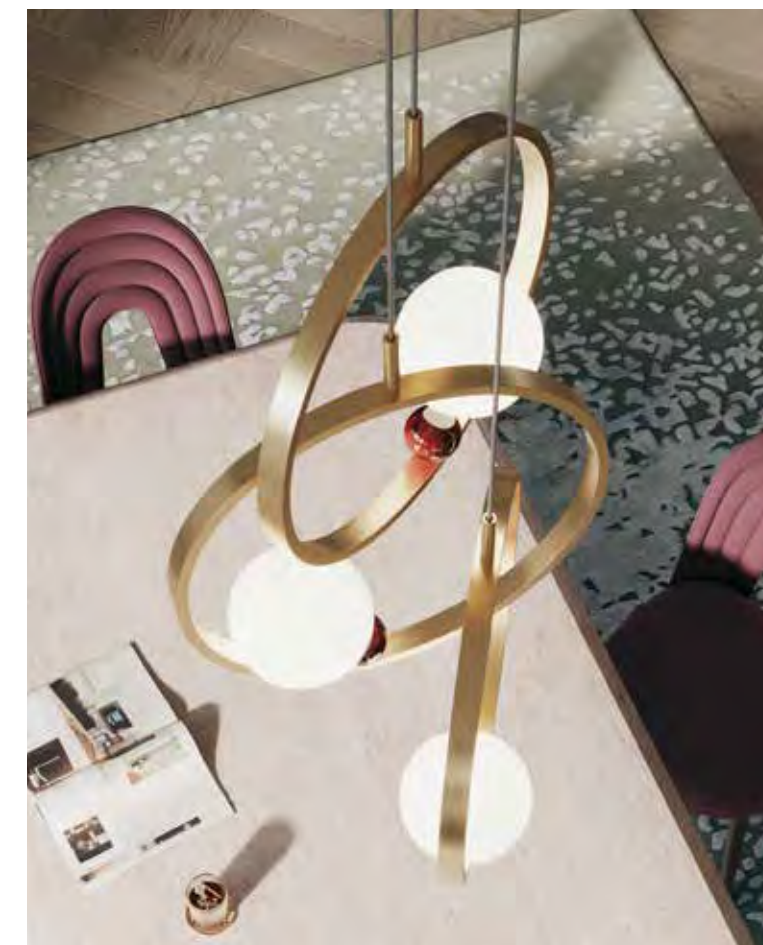

Inspiration

Joy Wall

La composizione Joy nasce dal tema di dare corpo alla luce. La lampada è composta da un anello in ottone, e sfere in vetro soffiato satinato bianco opaco (sfera grande) e rosso amaranzo (sfera piccola) magicamente sospese all'interno della struttura metallica sottile. Un gioco di masse e di traiettorie circolari genera un disegno bilanciato di dinamiche gravitazionali. La luce emanata dalle sfere si diffonde sullo spazio circostante e irraggia il telaio. I riflessi dell'ottone contribuiscono a rendere l'atmosfera ancora più sofisticata e onirica.

Joy composition was born from the idea of giving form to light. The lamp is composed of a brass ring and spheres in hand-blown white satin glass (big sphere) and red see-through, (small sphere) magically suspended within a thin metal structure. The play of circular masses and trajectories generates a balanced design of gravitational dynamics. The light from the sphere is diffused into the surrounding space, illuminating the frame. The reflections of the brass render the luminous field visible by its aura.



Inspiration

Kalì Suspension



Chandelier di imponente scultorea che crea oniriche geometrie di luci tra bracci che sorreggono candele dorate. Kalì chandelier vanta una lavorazione creata interamente sulla isola di Murano da storici artigiani. I bracci metallici hanno terminali a sezione esagonale che reggono elementi in vetro che racchiudono all'interno frammenti di foglia oro 24 KT in dispersione. Sotto ai bracci inferiori sono inseriti degli spot light. Illuminazione a led. La lampada è rifinita in finitura oro opaco. Nella versione a 3 anelli il lampadario king size è perfetto per impreziosire ambienti importanti dalle ampie volumetrie.

Statuesque imposing chandelier, creating dreamlike light geometries among its hands bearing golden candles. Kalì chandelier is the result of an artisan handcraft totally made in Murano island. Made of brass, its metal hands - esagonal shaped- hold up glass elements enclosing 24 KT gold leaf particles. Under the below ring there are spot lights. Final finish matt gold. LED lighting. 3-rings model is a king size chandelier perfect for embellishing important halls with large volumes.

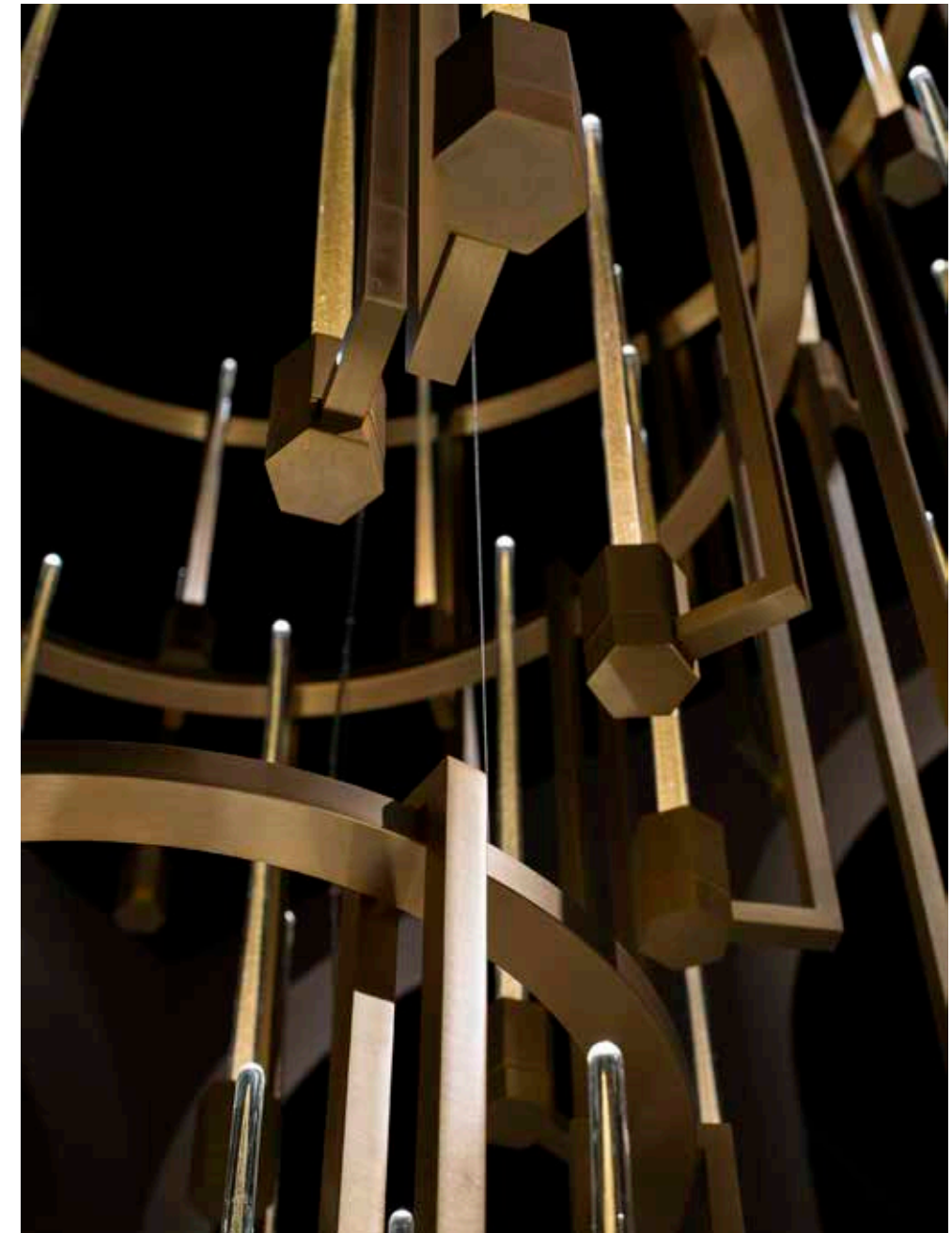

Kali Wall



Kali vanta una lavorazione creata interamente sulla isola di Murano da storici artigiani. Della linea fa parte anche questa versione applique, realizzata con due bracci in metallo finitura oro opaco che sorreggono elementi in vetro di Murano con foglia d'oro 24 KT all'interno, in dispersione.

Kali is the result of an artisan handcraft totally made in Murano island. Wall version of Kali chandelier is also part of this collection. It is realised with a metal hand with matt gold finish bearing two Murano glass elements enclosing 24 KT golden leaf.



Allure



La composizione Allure è un prezioso lampadario interamente realizzato a mano secondo le più antiche tradizioni muranesi. Il corpo delle 22 gocce (versione oval con 6 spot integrati) e 23 gocce (versione round, con 5 spot integrati), disposte ad altezze sfalsate, è realizzato in vetro di murano pieno, color cristallo veneziano, con incamiciata una preziosa foglia d'oro 24 kt. La bossola superiore è in ottone, e alloggia un moderno supporto a led. La bossola è infine ancorata su una piastra in acciaio, verniciata opaca in bianco RAL 9016, nero RAL 9005, oro.

È disponibile nelle versioni Oval (6 spot led) , Round (5 spot led) e Side.

The Allure is an exquisite lamp entirely handcrafted according to traditional murano techniques. The venetian crystal colour drops (n. 22 drops and 6 spots for oval version and n. 23 drops and 5 spots for round version), positioned at different heights, are made in solid murano glass enclosing precious 24 kt gold or silver leaf. In the gold finish, the top cap is made from brass and includes the modern led light support. The top plate is anchored to a steel plate painted matt white RAL 9016, black RAL 9005, gold.

It is available in versions: Oval with six integrated spots, Round with 5 integrated spots, and Side.



Allure Side



La composizione Allure è un prezioso lampadario interamente realizzato a mano secondo le più antiche tradizioni muranesi. La versione Side ha 6 gocce realizzate in vetro di murano pieno, color cristallo veneziano, con incamiciata una preziosa foglia d'oro 24 kt. La bossola superiore è in ottone e alloggia un moderno supporto a led, ed è ancorata su una piastra in acciaio, verniciata opaca in bianco RAL 9016, nero RAL 9005, oro. La versione Side può avere su richiesta come optional Spot led.

The Allure is an exquisite lamp entirely handcrafted according to traditional murano techniques. The Side version has 6 drops made in solid murano glass enclosing precious 24 kt gold. The top cap is made from brass and includes the modern led light support. The top plate is anchored to a steel plate painted matt white RAL 9016, black RAL 9005, gold. The Side version can have optional Spot Leds on request.



Inspiration

Circle



Una lampada decorativa da parete dalle dimensioni importanti ispirata alle linee morbide degli anni '40. Circle Lamp è realizzata attraverso un grande disco leggermente concavo in metallo martellato a mano e smaltato a specchio in diversi colori sul quale poggia al centro, come una goccia, una mezza sfera in metallo specchiato finitura oro lucido. Ogni pezzo della collezione è unico grazie alla preziosa lavorazione a mano.

A remarkable size decorative wall lamp, inspired by the soft lines of the 1940s. Circle Lamp consists of a slightly concave disc made of hand-hammered metal shiny gold and mirror glazed in various colors, on which a half sphere in reflective material sits like a drop. Thanks to hand-made manufacturing techniques, each piece of the collection is unique.



Inspiration

Galaxy



Galaxy è una lampada da parete che con le sue forme e riflessi diventa una vera e propria scultura. È composta da lenti convesse in finitura oro lucido, abbinata a dischi in metallo finitura bronzo ottone opaco. Le superfici lisce e convesse donano dinamicità allo spazio.

Galaxy is a wall lamp with shapes and reflexes that almost turns it into a sculpture. It comprises a number of convex metal elements, with gold, shiny finish that reflect different tones of light combined with metal discs matt bronzed brass. Smooth and convex surfaces bring dynamism to the space.

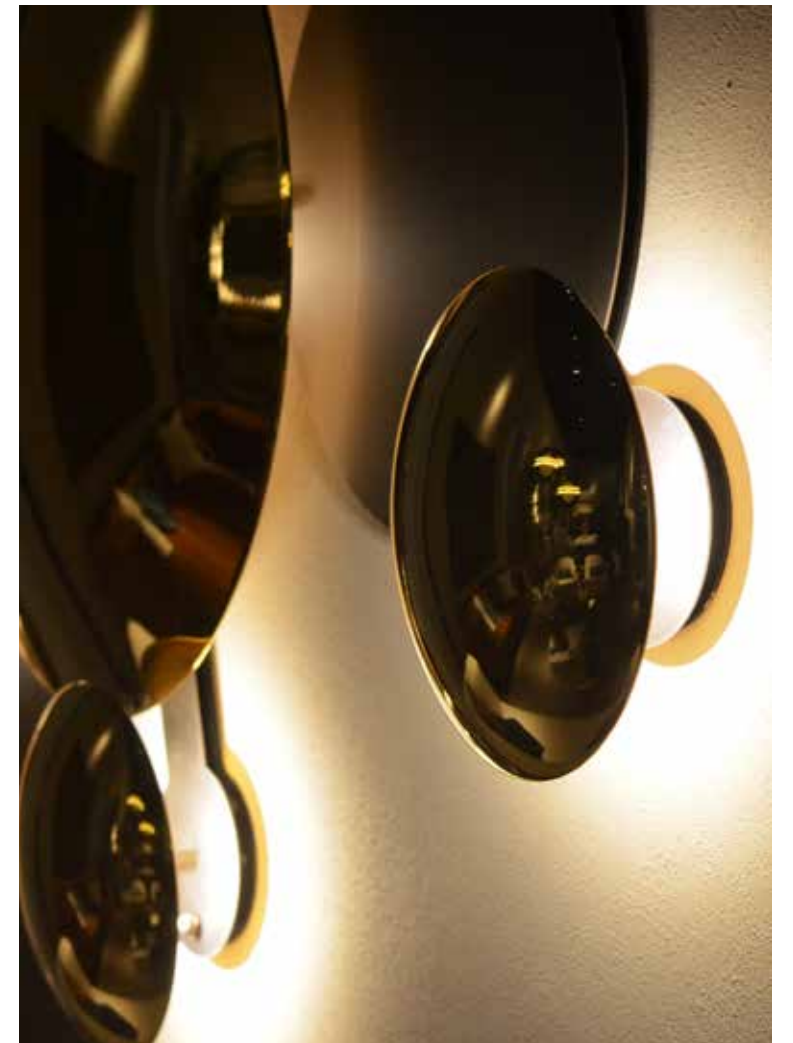

Labilis Composition



Un nuovo alfabeto grafico fatto di essenziali elementi geometrici che disegnano nello spazio contemporanee forme di luce. Tre anelli di diverso diametro installabili singolarmente o in composizione da 4, 7 e 10 anelli. L'anello in metallo è finitura nero opaco con diffusore di luce led in policarbonato opalino bianco perimetrale. Ogni anello monta uno spot in ottone finitura bronzo ottone opaco. Gli anelli presentano tre cavi di sospensione, di cui uno di alimentazione. Cavi elettrici della lunghezza di due mt.

Optionals su richiesta: anelli dimmerabili; rosoni cilindrici in metallo con alimentatore interno, adatto per installazione a soffitto.

A new graphic alphabet consisting of essential geometric elements that create contemporary light forms in the space. Three rings in different diameters can be installed separately or as composition (4, 7, 10 rings). The metal ring is in satin black finish, with light diffuser in white opal polycarbonate along the perimeter. Each ring carries a LED spot in matt brass bronze finish. Each ring has three suspension cables, one of which is a power supply one. Electric cables are two meters long.

Optionals available on request: dimmable rings; metal cylindrical roses holding local drivers, suitable for ceiling installation.



Inspiration

Labilis Ring



Tre anelli di diverso diametro installabili singolarmente o in composizione da 4, 7 e 10 anelli. L'anello in metallo è finitura nero opaco con diffusore di luce led in policarbonato opalino bianco perimetrale. Ogni anello monta uno spot in ottone finitura bronzo ottone opaco. Gli anelli presentano tre cavi di sospensione, di cui uno di alimentazione. Cavi elettrici della lunghezza di due mt.

Optionals su richiesta: anelli dimmerabili; rosone cilindrico in metallo con alimentatore interno, adatto per installazione a soffitto.

Three rings of different diameters can be installed separately or as composition (4, 7, 10 rings). The metal ring is in satin black finish, with light diffuser in white opal polycarbonate along the perimeter. Each ring carries a LED spot in matt brass bronze finish and has three suspension cables, one of which is a power supply one. Electric cables are two meters long.

Optionals available on request: dimmable rings; metal cylindrical rose holding local driver, suitable for ceiling installation.



Labilis Wall



Tre anelli di diverso diametro installabili a parete singolarmente o in composizione libera. L'anello in metallo è finitura nero opaco con diffusore di luce led in policarbonato opalino bianco perimetrale. Ogni anello è fissato a parete da un cilindro metallico in finitura bronzo opaco e da due distanziatori in metallo finitura nero opaco. Alimentatore remoto. Optional su richiesta: anelli dimmerabili.

Three rings of different diameters that can be installed on the wall individually or in random composition. The metal ring has a matt black finish with a white opal polycarbonate LED light diffuser around the perimeter. Each ring is fixed to the wall by a metal cylinder in matt brass bronze finish and by two metal spacers in matt black finish. Remote power supply. Optional on request: dimmable rings.



Inspiration

Fair Light



Fair Light è un corpo illuminante da parete costituito da un doppio binario di tubolari in metallo finitura nero opaco con diffusore in policarbonato opalino. La struttura di ancoraggio alla parete, che incorpora il driver, è in metallo finitura bronzo ottone opaco. L'apparecchio può essere montato sia in verticale che in orizzontale garantendo alla sorgente luminosa lineare un'ampia capacità di espressione, fornendo allo spazio energia e carattere.

Fair Light is a wall light fitting consisting of a double track made of black matt metal tubular elements with opal polycarbonate diffuser. The structure that anchors it to the wall incorporates the driver and is made of matt bronzed brass finished metal. The light can be fitted vertically or horizontally, guaranteeing the linear light source a broad capacity of expression, conveying energy and character to the room.

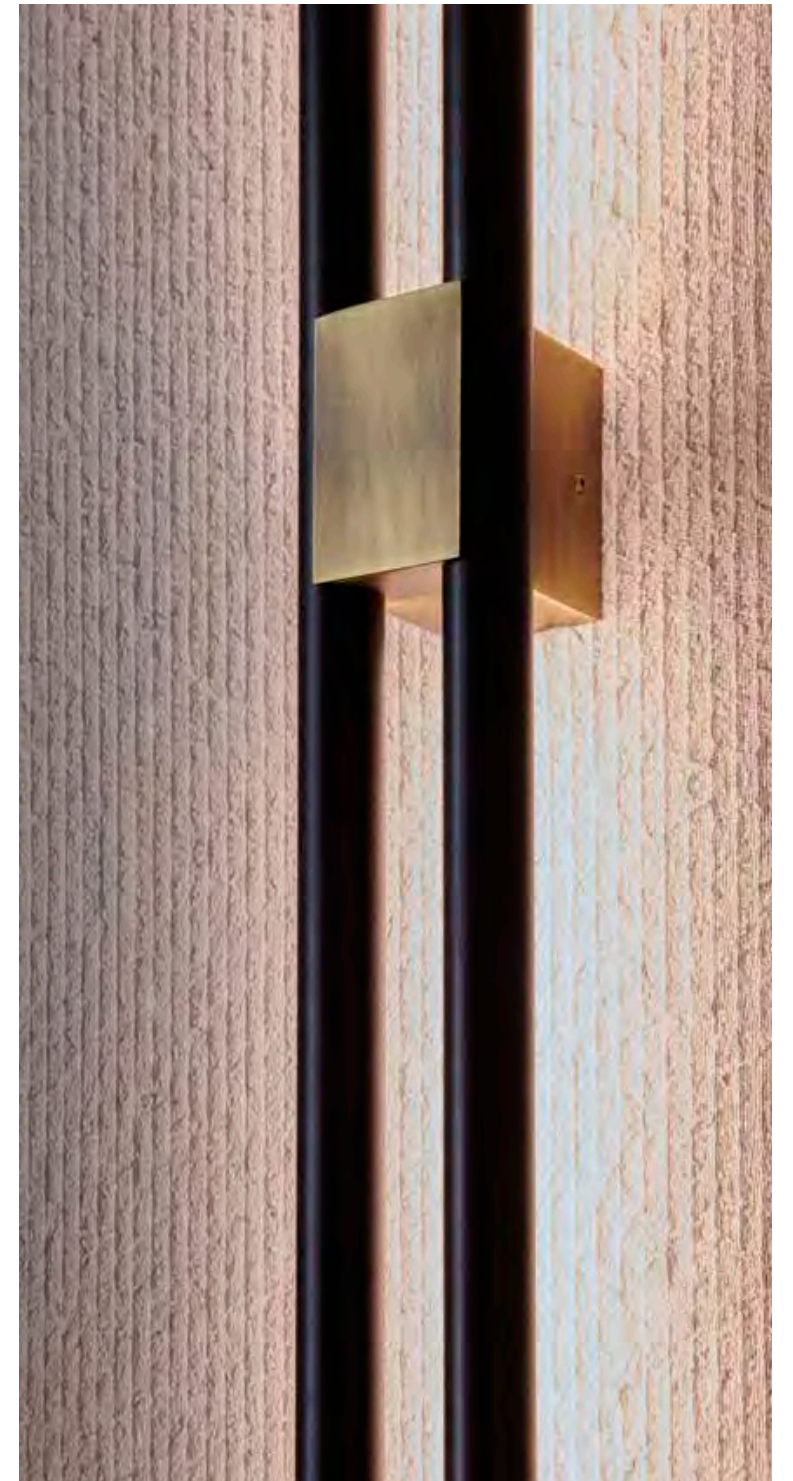

Inspiration

Stellantis



Stellantis è una scultura luminosa sospesa, immaginata per diventare il centro focale dell'ambiente. Suggestiva e poetica, è composta da sei coni in vetro con sfumatura metallizzata bronzo - realizzati su misura dai maestri vetrai di Murano - fissati su un'asta verticale in ottone. Illuminati da sorgente a LED, gli elementi in vetro diffondono nell'ambiente riflessi cangianti con un effetto espressivo e scenografico. Anche dimmerabile.

Stellantis is a suspended light sculpture, designed to become the focal point of the environment. Suggestive and poetic, it is a composition of six glass cones with a metallic bronze shade - custom made by Murano glass masters - fixed on a vertical brass rod. Illuminated by a LED source, the glass elements diffuse iridescent reflections into the environment with an expressive and scenographic effect. Also dimmable.

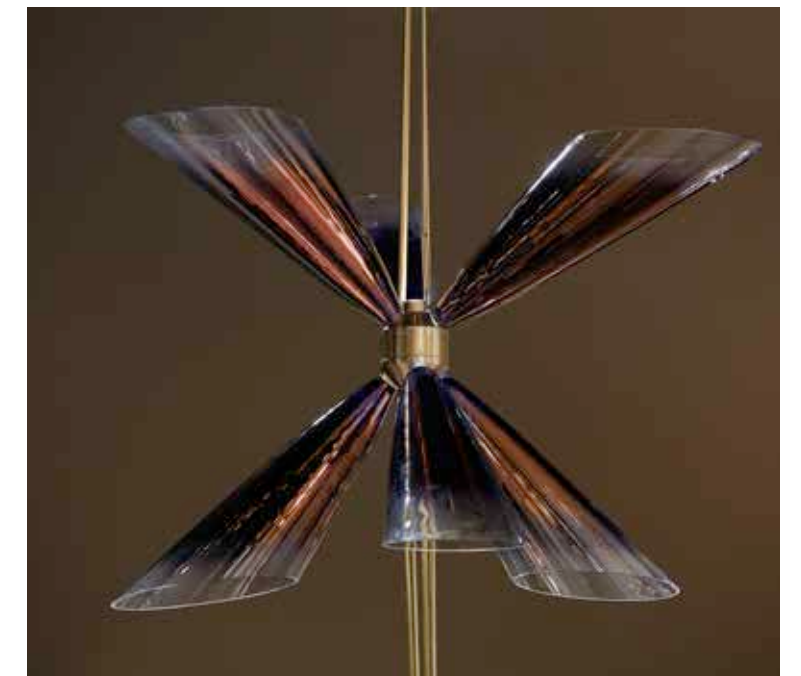

Inspiration

Venus



Venus diventa un elemento scenografico capace di rendere con la sua suggestiva lavorazione ogni ambiente ricco di una sofisticata luminosità.
È composto da un ricco bouquet di elementi metallici a sezione semicircolare e stecche in vetro di murano in cristallo con inclusioni di scaglie oro 24 KT, posti ad altezze sfalsate e raccolti in una fascia metallica luminosa di forma circolare o ovale, trattata con particolare finitura oro opaco a più strati.

Venus is a cinematic element which makes every space rich with a sophisticated brilliance thanks to its suggestive manufacturing.
It consists of a rich bouquet of semicircular section metallic elements and Murano glass slats including gold 24 KT flakes, placed at staggered heights and collected in an oval or circular metal band, treated with special finish matt gold.



Wave



Il lampadario Wave è realizzato con una struttura in metallo di forma ovale, con una speciale finitura oro opaco, che accoglie gli elementi in vetro borosilicato a sezione triangolare di diverse altezze creando un effetto onda lungo tutto il perimetro. All'interno del perimetro curviforme è posizionata una piastra illuminante con struttura in metallo e pannello in policarbonato opalino che diffonde la luce.

The Wave chandelier is made of an oval-shaped metal structure, with a special matt gold finish, which houses the borosilicate glass elements in triangular section of different heights creating a wave effect along the entire perimeter. Inside the curviform perimeter there is a lighting plate with a metal structure and an opal polycarbonate panel that diffuses the light.



Roulette



Lampada a sospensione di forma cilindrica composta da una struttura in metallo finitura bronzo con paralume interno/esterno in tessuto color avorio, al suo interno è alloggiata una moderna sorgente led. Il paralume è impreziosito esternamente da una fascia esterna rivestita con prezioso tessuto in fibra naturale di colore bronzo scuro, intrecciata manualmente.

Cylindrical shaped suspension lamp composed of a metal structure with a bronze metal finish and an inner/outer shade in ivory-coloured fabric, within which a modern LED light source is housed. The lampshade is embellished externally by a band covered with a fine, hand-woven natural fibre fabric of a dark bronze colour.



Inspiration

Colette & Hugo



Dalla maestria degli artigiani vetrai di Murano nasce questa amabile coppia di lampade da tavolo. Ne viene proposto un ensemble per enfatizzare la perfetta armonia di forma e stile, amabili tuttavia anche singolarmente per conferire un tocco sofisticato a qualsiasi tipo di ambientazione. La base è a forma di goccia, realizzata in vetro di Murano con all'interno polvere d'oro 24 KT in sospensione, e paralume in tessuto percale realizzato artigianalmente, Hugo, più compatta, ha una forma piena e morbida ed un cappello cilindrico, mentre Colette è slanciata e leggermente più alta, con un paralume rastremato.

Thanks to the Murano glass hand craftsmanship virtuosity, a lovely couple of table lamp has appeared. This ensemble emphasizes the perfect shape and style harmony that can be appreciated also in their singularity in order to give a sophisticated touch to every kind of set. The drop-shape base is made of Muranese glass enclosing a 24 KT golden leaf, the lampshade is in a hand made fabric percale. Hugo, more compact, has a full and soft shape and a cylindrical lampshade; otherwise, Colette is slim and a bit higher with a tapered lampshade.



Inspiration

Nettuno Table



Coppia di lampade da tavolo che completa la collezione Nettuno (tavolo, desk e coffee table). Il corpo in vetro scanalato a mano ha forma di parallelepipedo e viene presentato di colore e altezze diverse. Il corpo più slanciato è di colore rosa antico, mentre quello più compatto è di color pagliesco, entrambi reggono un portalampada con due lampadine E27.

Il paralume in tessuto percale color avorio, l'accensione a catenella e il cavo di alimentazione in tessuto color oro contribuiscono a creare una silhouette calda e sofisticata. Entrambi i modelli possono essere realizzati in color rosa antico o pagliesco. È disponibile in due dimensioni.

Pair of table lamps that complete the Nettuno collection (table, desk and coffee table). The body in hand-grooved glass in the shape of a parallelepiped is presented in different colours and heights. The more slender body is in antique pink, while the more compact body is straw-coloured; both are fitted with a lamp holder for two E27 bulbs.

The ivory-coloured percale fabric lampshade, the chain-style pull-cord and the gold-coloured fabric power supply cable contribute to creating a warm and sophisticated silhouette. Both lamps can be made in antique pink or straw-coloured glass. It is available in two sizes.



Ambra Table



Ambra è l'abat-jour ideale per creare dei caldi ed eleganti punti luce in salotti, camere padronali e raffinate suite. Questa lampada è composta da un'asta in ottone con finitura bronzo ottone opaco nella quale sono inseriti e ruotano dischi in lucite alternati a metallo che creano un sofisticato gioco di trasparenze e riflessi di luci. Ambra è completata nella parte superiore da un prezioso cappello in tessuto misto viscosa col. crema, impreziosito ai bordi da un'elegante passamaneria in tinta.

Ambra is the ideal table lamp to create warm and elegant lighting points in lounges, master bedrooms and elegant suites. It comprises a brass rod with a matt bronzed brass finish on which lucite rotating discs alternate with metal, creating a sophisticated transparency and light reflection. Ambra is finished with an exquisite lampshade in viscose blended fabric col. cream, enriched at the edges with precious coordinated braid.



Inspiration

Pablo Table



Lampada con base dalla forma asimmetrica realizzata in ceramica artigianale di Faenza color bianco in cui si alternano elementi in finitura lucida, con elemento a uovo realizzato in selenite. Il paralume -100% naturale- è realizzato in fibra di canapa nepalese. Sorgente luminosa E27.

An asymmetrically shaped lamp, handmade with white Faenza ceramic base, featuring elements with a high-gloss finish alternating with an egg-shaped element made of selenite. The 100% natural lampshade is made of Nepalese hemp fibre. Lighting source E27 bulb.



Hyperbole Table



Lampada con base in granito antico nero a texture rigata. Il paralume -100% naturale- è realizzato in fibra di banano e presenta una finitura interna rame satinato opaco. Sorgente luminosa E27.

A lamp with a black antique granite striped base. The 100% natural lampshade is made of banana leaf fibre, with the inner copper matt satin finish. Lighting source E27 bulb.



Oscar Table



Lampada con base realizzata in ceramica artigianale di Faenza color bianco opaco. Il paralume -100% naturale- è realizzato in fibra di canapa nepalese. Sorgente luminosa E27.

Lamp with base made of white matt handmade Faenza ceramic. The 100% natural lampshade is made of Nepalese hemp fibre. Lighting source E27 bulb.



Kaala Table



Lampada con base in metallo color champagne opaco, ricoperto da lastre realizzate in ceramica artigianale di Vietri smaltata bianca o gialla. L'accostamento dei due materiali crea un elegante inserto metallico. Il paralume -100% naturale- è realizzato in fibra di canapa nepalese color turchese o beige. Sorgente luminosa E27.

A lamp made of matt champagne-coloured metal structure, covered by handmade white or yellow-glazed Vietri ceramic. The combination of two materials creates an elegant metal trim. The 100% natural lampshade is made of Nepalese, turquoise or beige, hemp fibre. Lighting source E27 bulb.



Icone Luminose



Lampade da terra con struttura in metallo finitura oro opaco satinato, composta da vasi in vetro soffiato di Murano.

Floor lamps made of metal structure in matt gold finish. It is composed of vases in Muranese blown glass.



Icone Luminose Table



La serie di lampade della collezione Morandi si arricchisce di una nuova lampada versione da tavolo. Il corpo è composto da un vaso in vetro soffiato di Murano nelle forme e colori Ambra e Fumè che offrono un tocco sofisticato a qualsiasi tipo di ambientazione. Il paralume è in tela naturale realizzato artigianalmente.

The series of lamps of the Morandi collection is enriched with a new table version lamp. The body is composed of a blown Murano glass vase in the shapes and Amber and Fumè colors which offer a sophisticated touch to any type of setting. The lampshade is in natural canvas handcrafted.



TECHNICAL DATA





ANODINE CIRCLE LIGHT

Finishes of the above picture

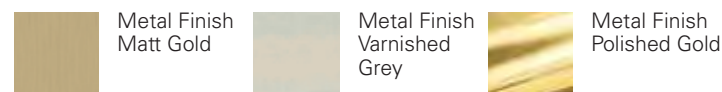

TECHNICAL SHEET
ANODINE CIRCLE LIGHT
 Light source: Strip LED 8 W/M + LED COB 36 W
 Total power: 43,2W
 Voltage: 115-230V
 Rated luminous flux: 4785 Lm
 Colour temperature: 2700° K
 Colour rendering index: Ra80/85
 Dimmer function: No
 Weight: Kg 17
 Package size: 118x118x38 cm
 Package weight: Kg 52

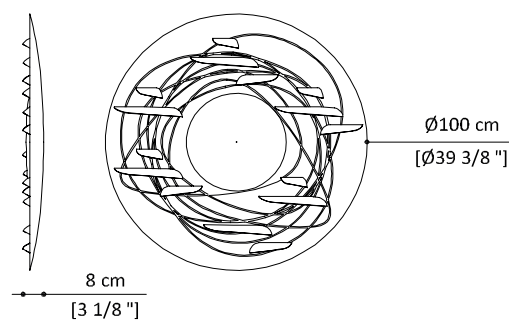

ANODINE FLOOR

Finishes of the above picture

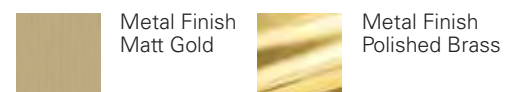

TECHNICAL SHEET
ANODINE FLOOR
 Light source: Power LED COB
 Total power: 24,5W
 Voltage: 54V
 Rated luminous flux: 2765 Lm
 Colour temperature: 3000° K
 Colour rendering index: Ra85
 Dimmer function: No
 Weight: Kg 10
 Package size: 200x52x52 cm
 Package weight: Kg 45

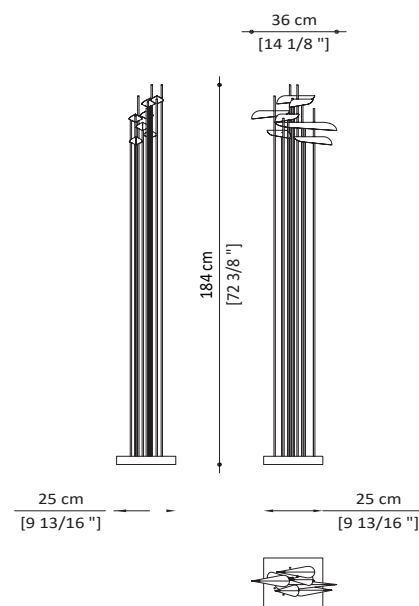

ANODINE TABLE & MINI

Finishes of the above picture

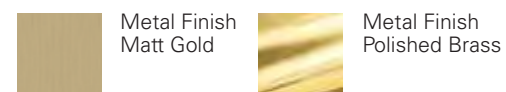

TECHNICAL SHEET
ANODINE TABLE
 Light source: Power LED COB
 Total power: 13x3,15 W (41 W)
 Voltage: 110-295V
 Rated luminous flux: 5135 Lm
 Colour temperature: 3000° K
 Colour rendering index: Ra85
 Dimmer function: No
 Weight: Kg 10
 Package size: 117x37x97 cm
 Package weight: Kg 56

TECHNICAL SHEET
ANODINE MINI
 Light source: Power LED COB
 Total power: 10,5W
 Voltage: 120V
 Rated luminous flux: 1185 Lm
 Colour temperature: 3000° K
 Colour rendering index: Ra85
 Dimmer function: No
 Weight: Kg 3
 Package size: 37x37x83 cm
 Package weight: Kg 18

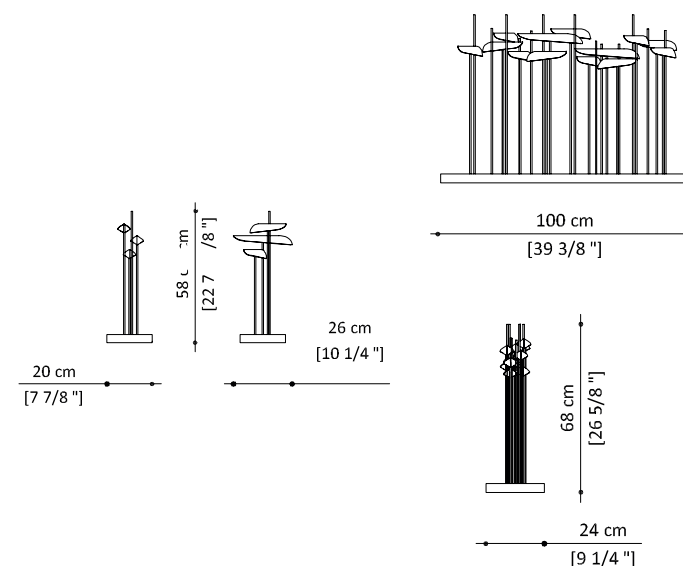

ANODINE WALL

Finishes of the above picture



TECHNICAL SHEET
ANODINE WALL
 Light source: Power LED COB
 Total power: 11W
 Voltage: 220-240V
 Rated luminous flux: 1200 Lm
 Colour temperature: 3000° K
 Colour rendering index: Ra80
 Dimmer function: No
 Weight: Kg 0,197
 Package size: 72x52x68 cm
 Package weight: Kg 13
 Package volume: m³ 0,09

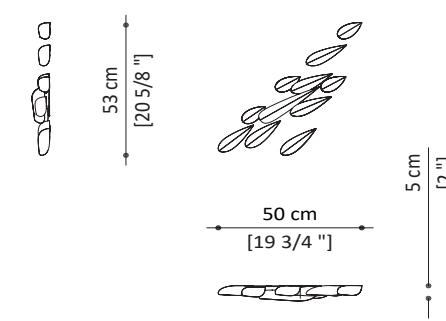



FANUS SUSPENSION

Finishes of the above picture



TECHNICAL SHEET
FANUS SUSPENSION
Light source: CC LED
Total power: 16,6W
Input Voltage(driver): 220-240V
Rated luminous flux: 1800 Lm
Colour temperature: 3000° K
Colour rendering index: 80
Dimmer function: No

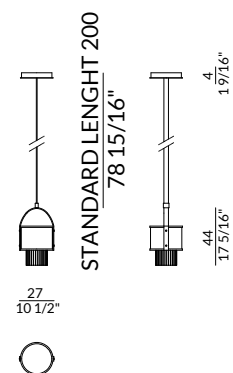

FANUS FLOOR

Finishes of the above picture

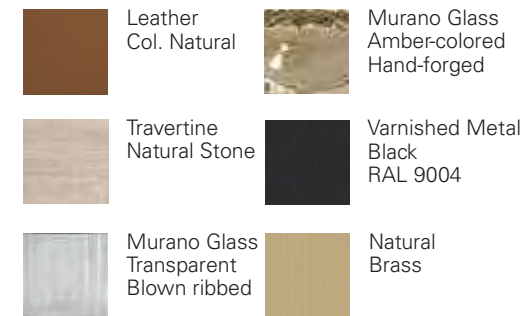

TECHNICAL SHEET
FANUS FLOOR
Light source: CC LED
Total power: 16,6W
Input Voltage(driver): 220-240V
Rated luminous flux: 1800 Lm
Colour temperature: 3000° K
Colour rendering index: 80
Dimmer function: No

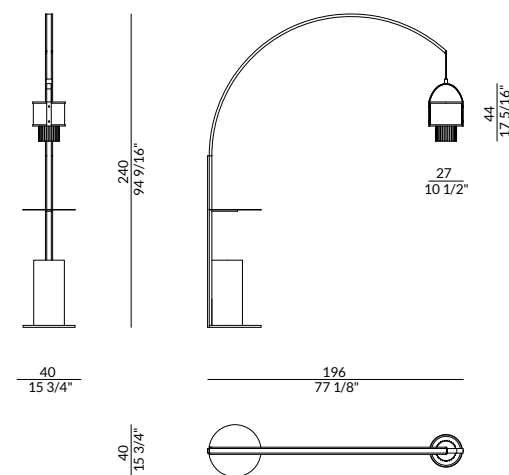

FANUS TABLE

Finishes of the above picture



TECHNICAL SHEET
FANUS TABLE
Light source: CC LED
Total power: 2,1W
Voltage: Battery 3,7 V-2600mAh
Rated luminous flux: 300 Lm
Colour temperature: 3000° K
Colour rendering index: 84
Dimmer function: Dimmable touch

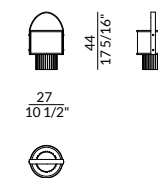

OUTDOOR COLLECTION



TERMINAL

Finishes of the above picture



TECHNICAL SHEET
TERMINAL
Light source: LED
Total power: 7W
Voltage: 220-240V
Rated luminous flux: 937 Lm
Colour temperature: 3000° K
Colour rendering index: Standard CRI>80
Dimmer function: No
Weight: Kg 5

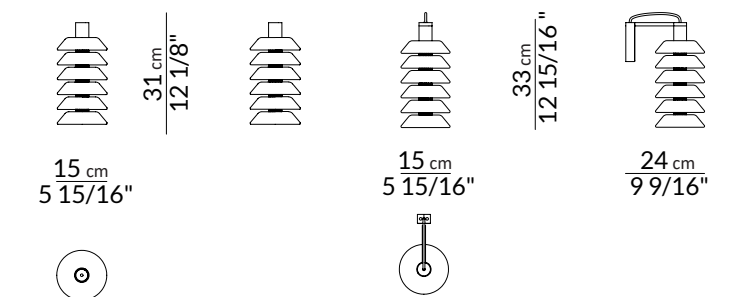



MANTA SUSPENSION

Finishes of the above picture

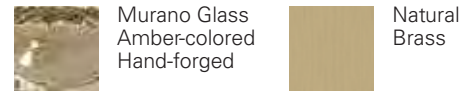

TECHNICAL SHEET
MANTA SUSPENSION
Light source: LED
Total power: 10W
Voltage: 220-240 V
Rated Luminus Flux: 800 Lm
Colour temperature: 3000°K
Color Rendering Index: Standard CRI>80
Suspension cable lenght: 200 cm
Dimmer function: No
Weight: Kg 3

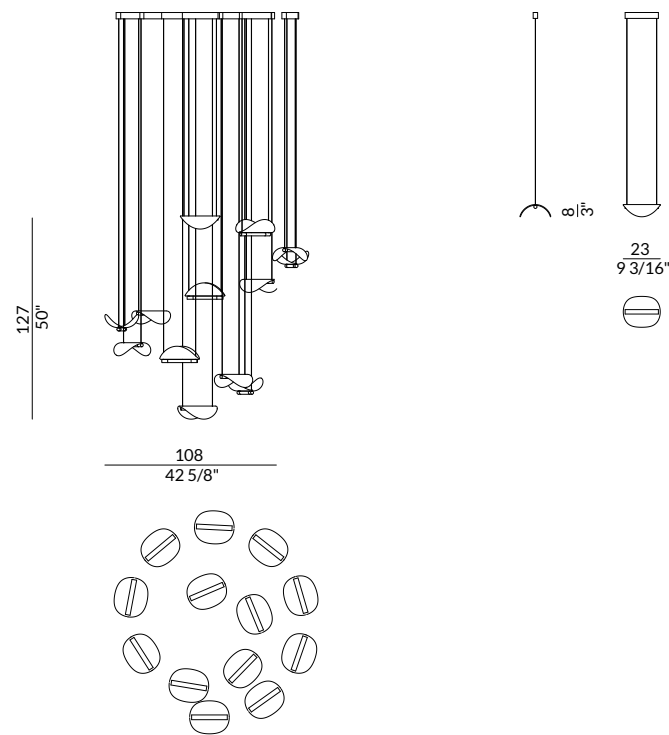

MANTA FLOOR

Finishes of the above picture

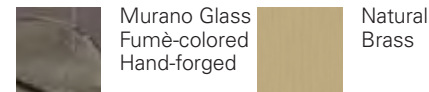

TECHNICAL SHEET
MANTA FLOOR
Light source: LED
Total power: 10 W
Voltage: 220-240 V
Rated Luminus Flux: 800 Lm
Colour temperature: 3000°K
Color Rendering Index: Standard CRI>80
Dimmer function: No

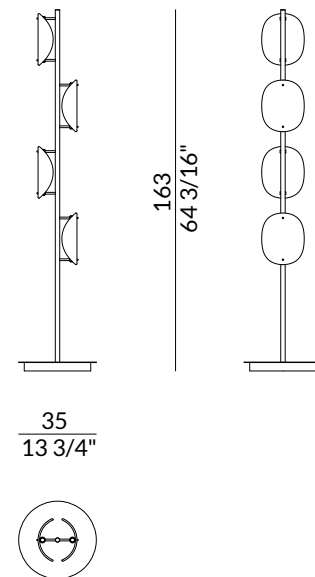

MANTA TABLE

Finishes of the above picture

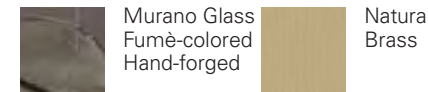

TECHNICAL SHEET
MANTA TABLE
Light source: LED
Total power: 10 W
Voltage: 220-240 V
Rated Luminus Flux: 800 Lm
Colour temperature: 3000°K
Color Rendering Index: Standard CRI>80
Dimmer function: No

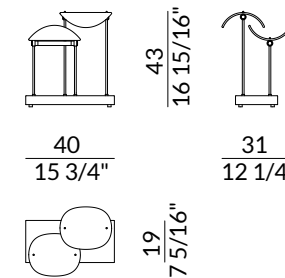

SORELUNA

Finishes of the above picture



TECHNICAL SHEET
SORELUNA
Light source: Board Led Ø80 (3X)
Total power: 15,6W - Board 5,2W(3X)
Voltage: 220-240 V
Rated luminous flux: 2538 Lm - (846Lm X3)
Colour temperature: 3000° K
Colour rendering index: >80
Dimmer function: No
Plug Cables Lenght: 2,5 mt
Light source cables lenght: 4mt
Weight: 3,5 Kg
Package size: 45x23X25 cm
Package weight: 5Kg

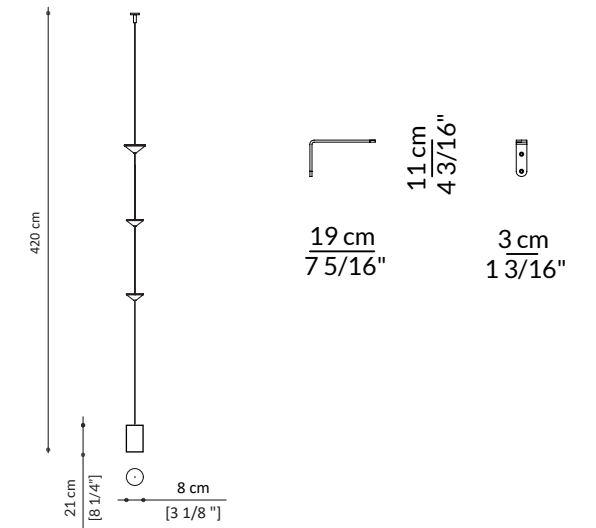



MY LAMP ROUND

Finishes of the above picture



Metal Finish
Matt Gold

Alternative finishes options



Metal Finish
Matt Black
Nickel

TECHNICAL SHEET

MY LAMP ROUND 50

Light source: STRIP LED 8W/M

Total power: 55W

Voltage: 110-240V

Rated luminous flux: 4420 Lm

Colour temperature: 2700° K

Colour rendering index: Ra80

Suspension cable length: 150 cm

Dimmer function: Yes

Weight: Kg 40

Package size: 71x71x78 cm

Package weight: Kg 65

TECHNICAL SHEET

MY LAMP ROUND 100

Light source: STRIP LED 8W/M

Total power: 128W

Voltage: 115-230V

Rated luminous flux: 9750 Lm

Colour temperature: 2700° K

Colour rendering index: Ra80

Dimmer function: Yes

Weight: Kg 130

Package size: 125x125x90 cm

Package weight: Kg 170

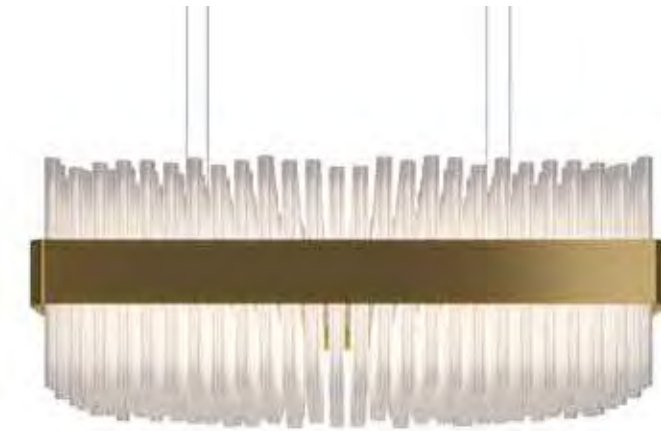

MY LAMP RECTANGULAR

Finishes of the above picture



Metal Finish
Matt Gold

Alternative finishes options



Metal Finish
Matt Black
Nickel

TECHNICAL SHEET

MY LAMP SQUARE

Light source: STRIP LED 8W/M

Total power: 115W

Voltage: 110-230V

Rated luminous flux: 9360 Lm

Colour temperature: 2700° K

Colour rendering index: Ra80

Suspension cable length: 200 cm

Dimmer function: Yes

Weight: Kg 100

Package size: 111x111x93 cm

Package weight: Kg 155

TECHNICAL SHEET

MY LAMP RECTANGULAR

Light source: STRIP LED 12W/M

Total power: 132W

Voltage: 12V

Rated luminous flux: 7200 Lm

Colour temperature: 2700° K

Colour rendering index: Ra80

Suspension cable length: 200 cm

Dimmer function: Yes

Weight: Kg 132

Package size: 125x125x90 cm

Package weight: Kg 200



MY LAMP SPHERE

Finishes of the above picture



Metal Finish
Matt Gold

Alternative finishes options



Metal Finish
Matt Black
Nickel

TECHNICAL SHEET

MY LAMP SPHERE

Light source: STRIP LED

Total power: 40W

Voltage: 12-24V

Rated luminous flux: 7200 Lm

Colour temperature: 2700° K

Colour rendering index: Ra>80

Suspension cable length: 150 cm

Dimmer function: Yes

Weight: Kg 36

Package size: 72x72x75 cm

Package weight: Kg 78



MY LAMP CEILING

Finishes of the above picture



Metal Finish
Matt Gold

Alternative finishes options



Metal Finish
Matt Black
Nickel

TECHNICAL SHEET

MY LAMP CEILING ROUND 100

Light source: STRIP LED 8W/M

Total power: 60,5W

Voltage: 115-230V

Rated luminous flux: 4615 Lm

Colour temperature: 2700° K

Colour rendering index: Ra80

Dimmer function: Yes

Weight: Kg 120

Package size: 125x125x90 cm

Package weight: Kg 160

TECHNICAL SHEET

MY LAMP CEILING ROUND 140

Light source: STRIP LED 11W/M

Total power: 108W

Voltage: 110-230V

Rated luminous flux: 11.500 Lm

Colour temperature: 2700° K

Colour rendering index: Ra80

Dimmer function: Yes

Weight: Kg 180

Package size: 160x160x90cm

Package weight: Kg 350

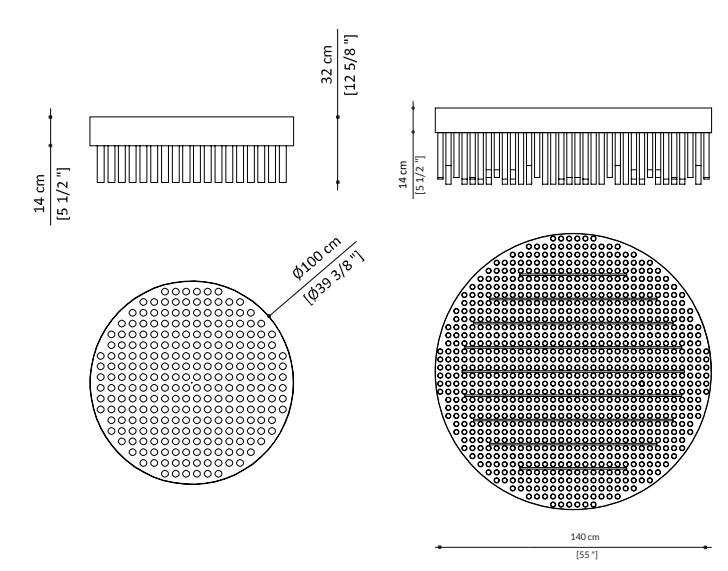
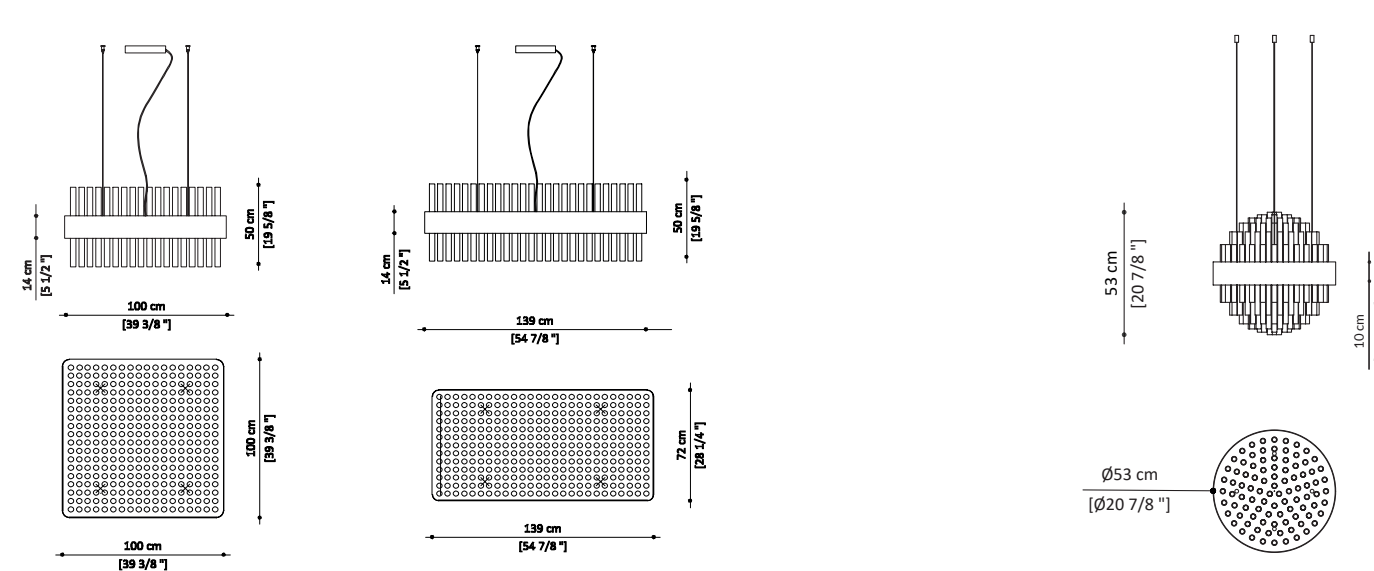
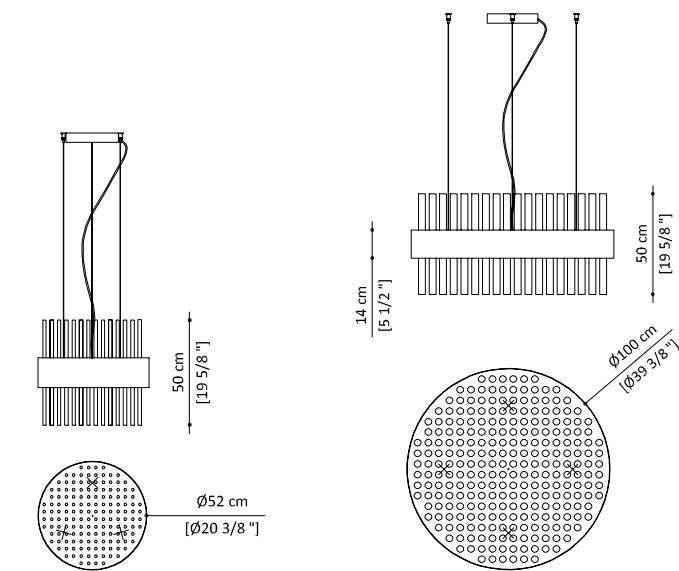

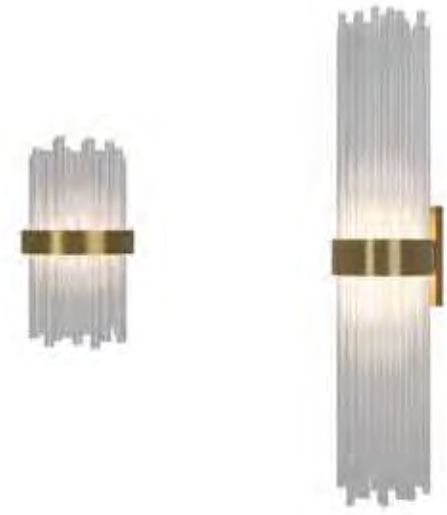

MY LAMP WALL

Finishes of the above picture



Metal Finish
Matt Gold

Alternative finishes options



Metal Finish
Matt Black
Nickel

TECHNICAL SHEET

MY LAMP WALL SMALL

Light source: LED
Total power: 15W
Voltage: 100-240V
Rated luminous flux: 1300 Lm
Colour temperature: 2700° K
Colour rendering index: Ra>80
Dimmer function: No
Weight: Kg 4
Package size: 130x30x50 cm
Package weight: Kg 15

TECHNICAL SHEET

MY LAMP WALL BIG

Light source: Strip LED 15 W/M
Total power: 52W
Voltage: 220-240V
Rated luminous flux: 4760 Lm
Colour temperature: 2700° K
Colour rendering index: Ra>80
Dimmer function: No
Weight: Kg 17
Package size: 200x77x48 cm
Package weight: Kg 65

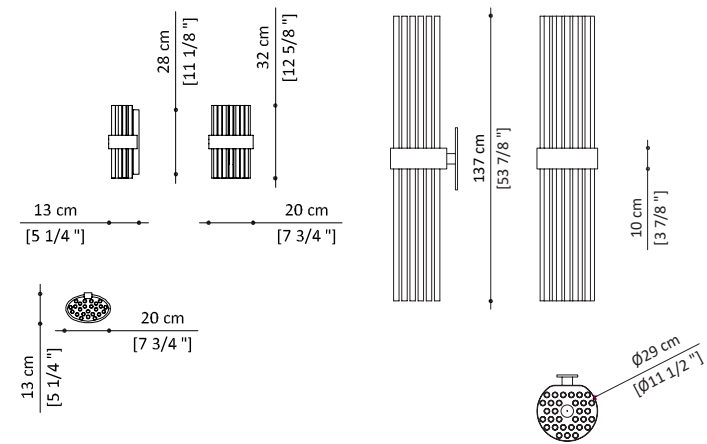

MY LAMP FLOOR

Finishes of the above picture



Metal Finish
Matt Gold

Alternative finishes options



Metal Finish
Matt Black
Nickel

TECHNICAL SHEET

MY LAMP FLOOR

Light source: 4 LED modules
Total power: 35W
Voltage: 240V
Rated luminous flux: 2600 Lm
Colour temperature: 2700° K
Colour rendering index: Ra80
Dimmer function: No
Weight: Kg 39
Package size: 160x76x60 cm
Package weight: Kg 78

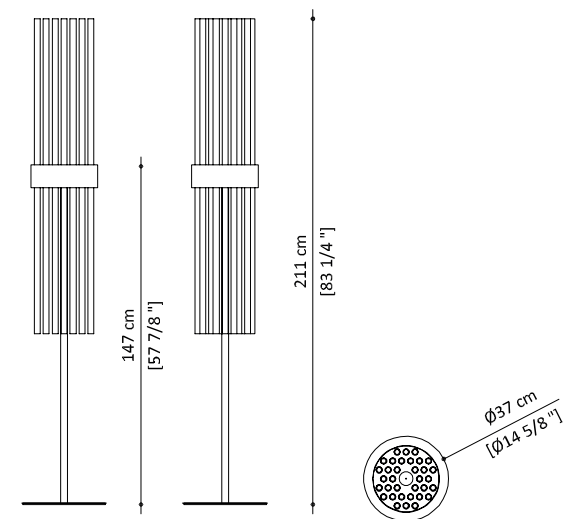

MY LAMP TABLE

Finishes of the above picture



Metal Finish
Matt Gold

Alternative finishes options



Metal Finish
Matt Black
Nickel

TECHNICAL SHEET

MY LAMP TABLE

Light source: Strip LED
Total power: 13W
Voltage: 240V
Rated luminous flux: 860 Lm
Colour temperature: 2700° K
Colour rendering index: Ra80
Dimmer function: No
Weight: Kg 4
Package size: 30x30x50 cm
Package weight: Kg 15

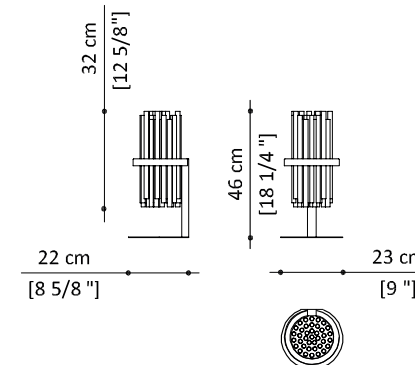

COMET FLOOR & TABLE

Finishes of the above picture



Fabric
Natural
col. Ivory



Matt
Brass



Oiled
Canaletto
walnut

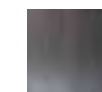

Wood with
acidetched zinc
finish

TECHNICAL SHEET

COMET FLOOR

Light source: LED
Total power: 40W
Voltage: 100-240V
Rated luminous flux: 1050 lm/mt
Colour temperature: 3000° K
Colour rendering index: Ra>90
Dimmer function: Si
Weight: 10 Kg
Package size: 150x85X25cm
Package weight: 20 Kg

TECHNICAL SHEET

COMET TABLE

Light source: LED
Total power: 24W
Voltage: 240V
Rated luminous flux: 1050 Lm/mt
Colour temperature: 3000° K
Colour rendering index: Ra>90
Dimmer function: Si
Weight: Kg 5
Package size: 65x57X20cm
Package weight: 12 kg

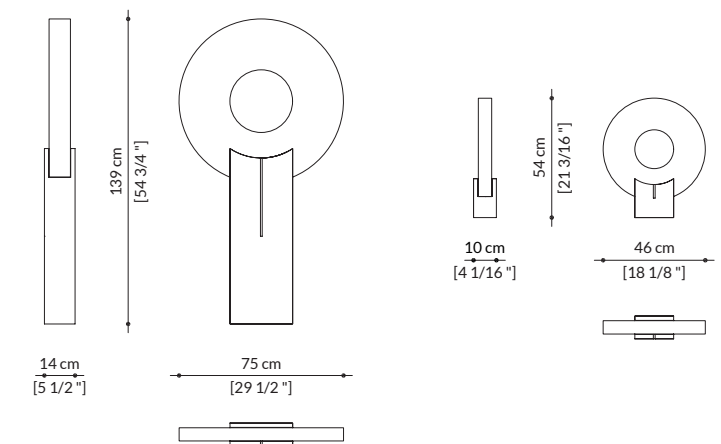



GOLDEN DISC SUSPENSION

Finishes of the above picture

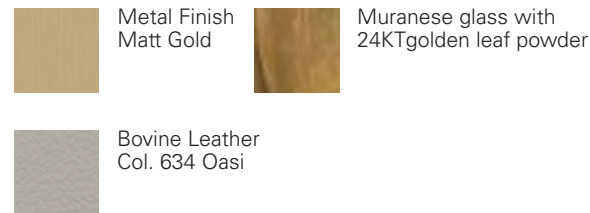

TECHNICAL SHEET
GOLDEN DISC SUSPENSION
Light source: LED
Total power: 4W
Voltage: 220-240V
Rated luminous flux: 315 Lm
Colour temperature: 3000° K
Colour rendering index: Ra>90
Dimmer function: No
Weight: Kg 10
Package size: 55x50x25 cm
Package weight: Kg 26
Package volume: Kg 0,10

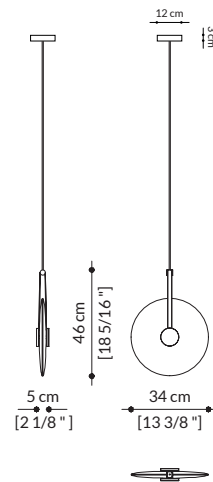

GOLDEN DISC WALL

Finishes of the above picture



TECHNICAL SHEET
GOLDEN DISC WALL
Light source: LED
Total power: 4W
Voltage: 220-240 V
Rated luminous flux: 315 Lm
Colour temperature: 3000° K
Colour rendering index: Ra>90
Dimmer function: No
Weight: Kg 10
Package size: 55x50x25 cm
Package weight: Kg 26
Package volume: Kg 0,10

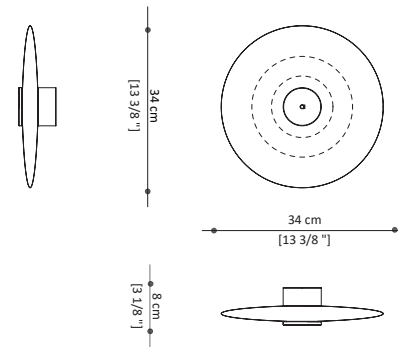

GOLDEN CLOUD SUSPENSION

Finishes of the above picture



TECHNICAL SHEET
GOLDEN CLOUD OVAL
Light source: LED
Glass elements power: 3Wx22
Spots power: 18W (6 x 3 W)
Voltage: 220-240V
Rated luminous flux: 5000 Lm
Colour temperature: 2700° K
Colour rendering index: Ra>80
Dimmer function: Yes - only for spots
Weight: Kg 71
Package size: 156x61x39 cm
Package weight: Kg 106
Package volume: Kg 0,37

TECHNICAL SHEET
GOLDEN CLOUD ROUND
Light source: LED
Glass element power: 3Wx23
Spots power: 15W (5 x 3 W)
Voltage: 220-240V
Rated luminous flux: 5000 Lm
Colour temperature: 2700° K
Colour rendering index: Ra>80
Dimmer function: Yes - only for spots
Weight: Kg 59
Package size: 96x96x57 cm
Package weight: Kg 94
Package volume: Kg 0,44

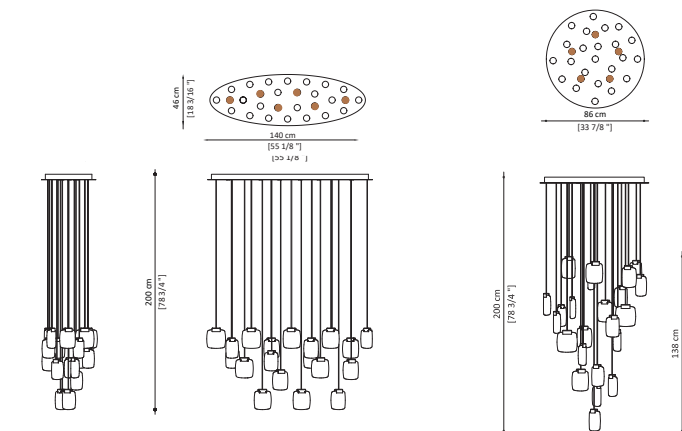

GOLDEN CLOUD WALL

Finishes of the above picture



TECHNICAL SHEET
GOLDEN CLOUD WALL
Light source: LED
Total power: 3W
Voltage: 220-240V
Rated luminous flux: 5000 Lm
Colour temperature: 2700° K
Colour rendering index: Ra>80
Dimmer function: No
Weight: Kg 2
Package weight: Kg 8

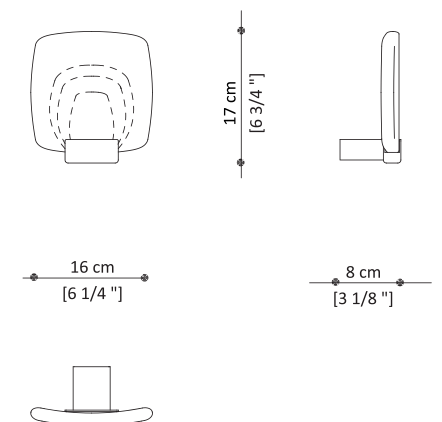



JOY SUSPENSION

Finishes of the above picture

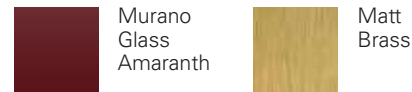

TECHNICAL SHEET JOY SUSPENSION 1 RING

Light source: LED
Total power: 1.9W
Voltage: 220-240V
Rated luminous flux: 204 Lm
Colour temperature: 2700° K
Colour rendering index: Ra>80
Dimmer function: No
Weight: Kg 10
Package size: 76x76x49 cm
Package weight: Kg 26
Package volume: Kg 0,28

TECHNICAL SHEET JOY SUSPENSION 3 RINGS

Light source: LED
Total power: 5.7W
Voltage: 220-240V
Rated luminous flux: 612 Lm
Colour temperature: 2700° K
Colour rendering index: Ra>80
Dimmer function: No
Weight: Kg 15
Package size 1: 68x68x31 cm
Package weight 1: Kg 5
Package volume: Kg 0,14
Package size 2: 45x47x35 cm
Package weight 2: Kg 13
Package volume: Kg 0,07

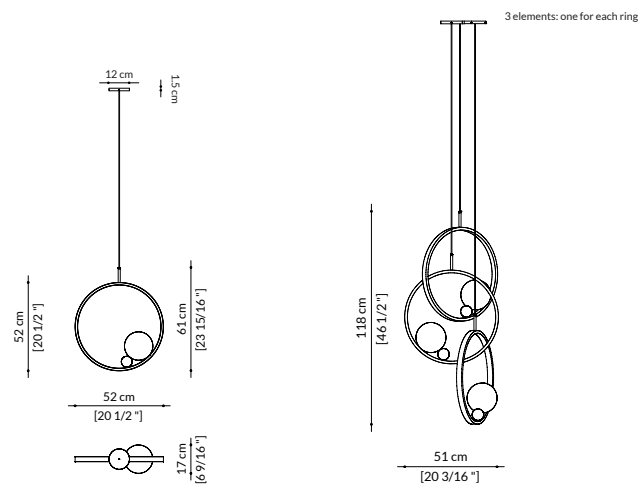

JOY WALL

Finishes of the above picture

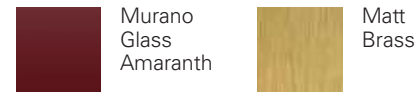

TECHNICAL SHEET JOY WALL

Light source: LED
Total power: 1.9W
Voltage: 220-240V
Rated luminous flux: 204 Lm
Colour temperature: 2700° K
Colour rendering index: Ra>80
Dimmer function: No
Weight: Kg 10
Package size: 72x75x45 cm
Package weight: Kg 30
Package volume: Kg 0,25

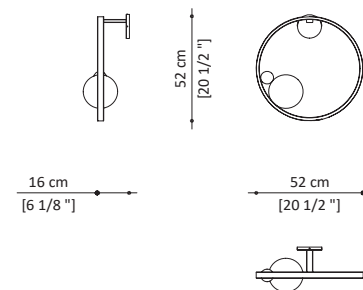

KALÌ SUSPENSION

Finishes of the above picture



TECHNICAL SHEET KALÌ SUSPENSION 2 RINGS

Light source: Power LED COB
Total power: 30 led spot x 1W + 6 led spotx3W
Voltage: 230V
Rated luminous flux: 6300 Lm
Colour temperature: 3000° K
Colour rendering index: Ra>80
Dimmer function: Yes - only for spots
Weight: Kg 100
Package size: 115x115x65 cm
Package weight: Kg 200

TECHNICAL SHEET KALÌ SUSPENSION 3 RINGS

Light source: Power LED COB
Total power: 58 led spot x 1W + 6 led spot x 3W
Voltage: 230V
Rated luminous flux: 10500 Lm
Colour temperature: 3000° K
Colour rendering index: Ra>80
Dimmer function: Yes - only for spots
Weight: Kg 160
Package size structure: 156x136x45 cm
Package weight structure: Kg 94
Package size glass candles: 100x60x70 cm
Package weight structure: Kg 100

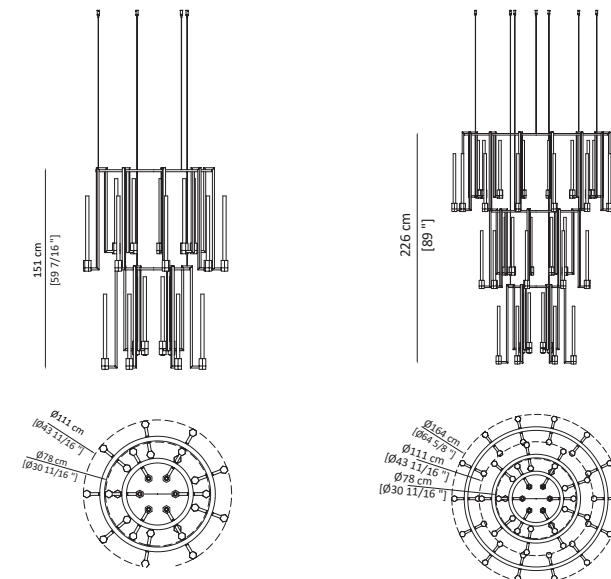

KALÌ WALL

Finishes of the above picture



TECHNICAL SHEET KALÌ WALL

Light source: 2 spot led x 2W
Total power: 4W
Voltage: 230V
Rated luminous flux: 300 Lm
Colour temperature: 3000° K
Colour rendering index: Ra80
Dimmer function: No
Weight: Kg 8
Package size: 80x40x40 cm
Package weight: Kg 15

TECHNICAL SHEET KALÌ WALL SINGLE

Light source: 2 spot led
Total power: 2W
Voltage: 230V
Rated luminous flux: 150 Lm
Colour temperature: 3000° K
Colour rendering index: Ra80
Dimmer function: No
Weight: Kg 4
Package size: 40x40x40 cm
Package weight: Kg 10

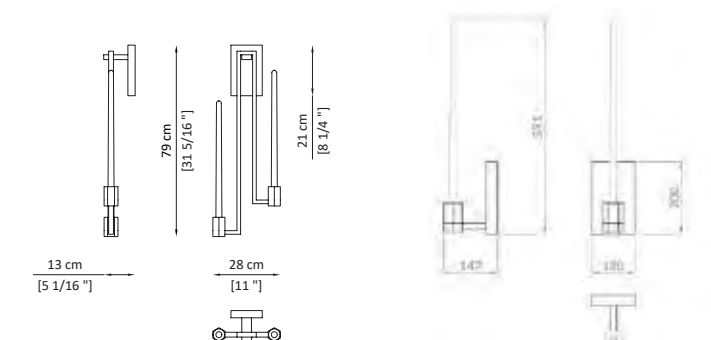



ALLURE

Finishes of the above picture



Satin Brass



Muranese glass with 24K golden leaf powder

TECHNICAL SHEET

ALLURE OVAL

Light source: Power LED
 Glass elements power: 23,1W (22x1,05W)
 Spots power: 18W (6x3W)
 Voltage: 220-240V
 Rated luminous flux: 5000 Lm
 Colour temperature: 3000° K
 Colour rendering index: Ra83
 Dimmer function: Yes - only for spots
 Weight: Kg 90
 Package size: 160x60x60 cm
 Package weight: Kg 106

TECHNICAL SHEET

ALLURE ROUND

Light source: Power LED
 Glass elements power: 24,15W (23x1,05W)
 Spots power: 15W (5x3W)
 Voltage: 220-240V
 Rated luminous flux: 2860 Lm
 Colour temperature: 3000° K
 Colour rendering index: Ra83
 Dimmer function: Yes - only for spots
 Weight: Kg 90
 Package size: 96x96x57 cm
 Package weight: Kg 106

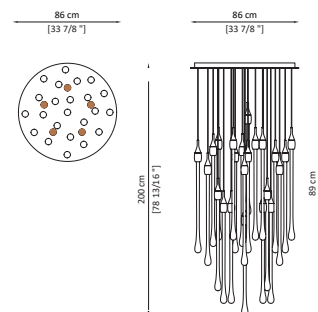
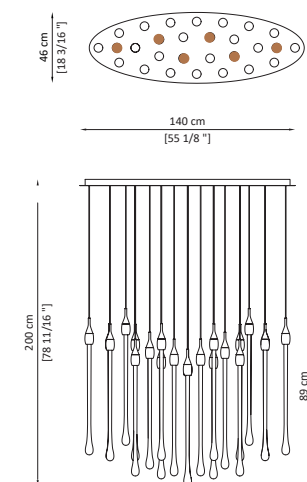

ALLURE SIDE

Finishes of the above picture



Satin Brass



Muranese glass with 24K golden leaf powder

TECHNICAL SHEET

ALLURE SIDE

Light source: Power LED
 Glass elements power: 6,30W (6x1,05W)
 Voltage: 220-240V
 Rated luminous flux: 2860 Lm
 Colour temperature: 3000° K
 Colour rendering index: Ra83
 Dimmer function: No
 Weight: Kg 52
 Package size: 68x84x57 cm
 Package weight: Kg 70
 Package volume: Kg 0, 33

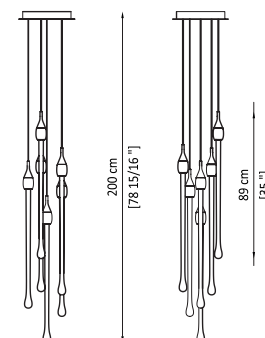
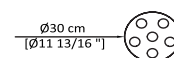

CIRCLE

Finishes of the above picture



Metal Finish Polished Gold



Metal Finish Varnished Bronze



Metal Finish Varnished Ivory

TECHNICAL SHEET

CIRCLE

Light source: Strip LED 8W/M
 Total power: 7,2W
 Voltage: 230V
 Rated luminous flux: 585 Lm
 Colour temperature: 2700° K
 Colour rendering index: Ra85
 Dimmer function: No
 Weight: Kg 15
 Package size: 118x118x38 cm
 Package weight: Kg 50

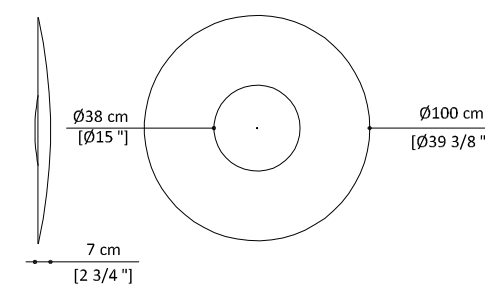

GALAXY WALL

Finishes of the above picture



Metal Finish Matt Bronzed Brass



Metal Finish Polished Gold

TECHNICAL SHEET

GALAXY

Light source: n.2 LED modules 22W - n.4 LED modules 11W
 Total power: 88W
 Voltage: 230V
 Rated luminous flux: 4880 Lm
 Colour temperature: 2700° K
 Colour rendering index: Ra85
 Dimmer function: No
 Weight: Kg 22
 Package size: 108x67x61 cm
 Package weight: Kg 67

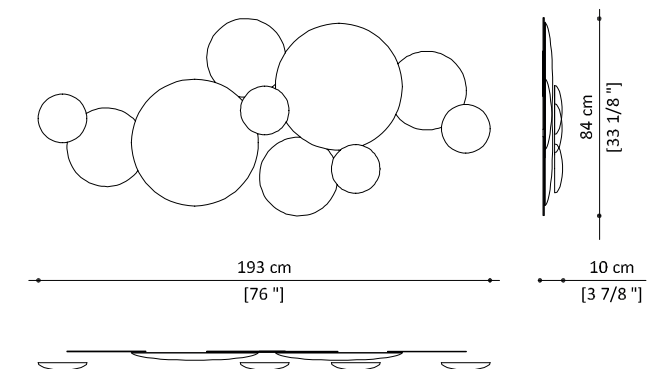



LABILIS SUSPENSION

Finishes of the above picture

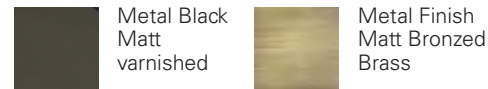

TECHNICAL SHEET LABILIS SUSPENSION 4 RINGS

Light source: Strip Led 140 Led/m + spot led (4X)
 Total power: 35W - Strip led 14,4W/m; spot 4,2W (10X)
 Voltage: 230V
 Rated luminous flux spots: 1320 Lm
 Rated luminous flux strip led: 6357 Lm
 Colour temperature: 2700° K
 Colour rendering index: 90
 Dimmer function: Yes - only for rings
 Cables lenght: 2mt
 Weight: 18 Kg

TECHNICAL SHEET LABILIS SUSPENSION 7 RINGS

Light source: Strip Led 140 Led/m + spot led (7X)
 Total power: 77W - Strip led 14,4W/m spot 4,2 W (7X)
 Voltage: 230V
 Rated luminous flux spots: 2310 Lm
 Rated luminous flux strip led: 14928 Lm
 Colour temperature: 2700° K
 Colour rendering index: 90
 Dimmer function: Yes - only for rings
 Cables lenght: 2mt
 Weight: 40 Kg

TECHNICAL SHEET LABILIS SUSPENSION 10 RINGS

Light source: Strip Led 140 Led/m + spot led (10X)
 Total power: 97W - Strip led 14,4W/m spot 4,2W (10X)
 Voltage: 230V
 Rated luminous flux spots: 3300 Lm
 Rated luminous flux strip led: 17541 Lm
 Colour temperature: 2700° K
 Colour rendering index: 90
 Dimmer function: Yes - only for rings
 Cables lenght: 2mt
 Weight: 48 Kg

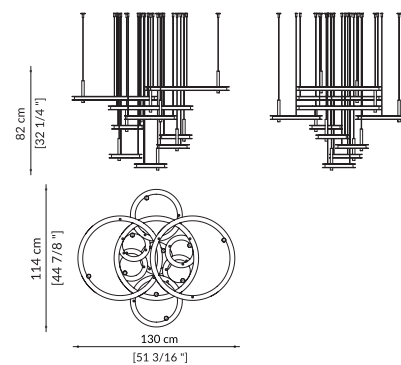
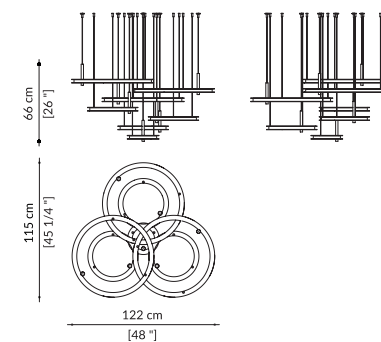
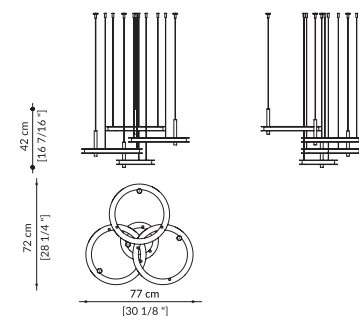

LABILIS RING

Finishes of the above picture

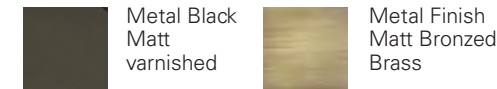

TECHNICAL SHEET LABILIS RING Ø27

Light source: Strip Led 140 Led/m + spot led
 Total power: 7,3W - Strip led 14,4W/m; spot 4,2W
 Voltage: 230V
 Rated luminous flux spot: 330 Lm
 Rated luminous flux strip led: 1092 Lm
 Colour temperature: 2700°K
 Colour rendering index: 90
 Dimmer function: Yes - only for ring
 Weight: 2,8 Kg

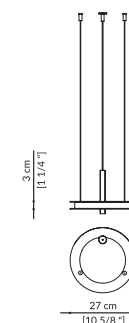

TECHNICAL SHEET LABILIS RING Ø43

Light source: Strip Led 140 Led/m + spot led
 Total power: 9,7W - Strip led 14,4W/m; spot 4,2W
 Voltage: 230V
 Rated luminous flux spots: 330 Lm
 Rated luminous flux strip led: 1755 Lm
 Colour temperature: 2700°K
 Colour rendering index: 90
 Dimmer function: Yes - only for ring
 Weight: 4,5 Kg

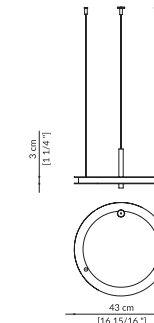

TECHNICAL SHEET LABILIS RING Ø70

Light source: Strip Led 140 Led/m + spot led
 Total power: 13,6W - Strip led 14,4W/m; spot 4,2W
 Voltage: 230V
 Rated luminous flux spots: 330 Lm
 Rated luminous flux strip led: 2857 Lm
 Colour temperature: 2700°K
 Colour rendering index: 90
 Dimmer function: Yes - only for ring
 Weight: 7,3 Kg

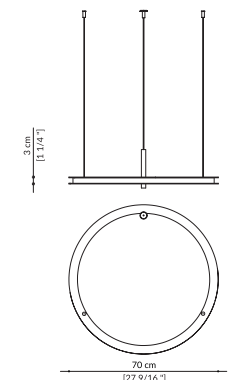



LABILIS WALL

Finishes of the above picture

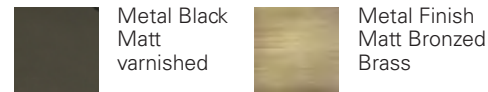

TECHNICAL SHEET
LABILIS WALL Ø27
Light source: Strip Led 140 Led/m
Total power: 7,3W - Strip led 14,4W/m
Voltage: 230V
Rated luminous flux strip led: 1092 Lm
Colour temperature: 2700°K
Colour rendering index: 90
Dimmer function: Yes
Weight: Kg 3

TECHNICAL SHEET
LABILIS WALL Ø43
Light source: Strip Led 140 Led/m
Total power: 9,7W - Strip led 14,4W/m
Voltage: 230V
Rated luminous flux strip led: 1755 Lm
Colour temperature: 2700°K
Colour rendering index: 90
Dimmer function: Yes
Weight: Kg 4

TECHNICAL SHEET
LABILIS WALL Ø70
Light source: Strip Led 140 Led/m
Total power: 13,6W - Strip led 14,4W/m
Voltage: 230V
Rated luminous flux strip led: 2857 Lm
Colour temperature: 2700°K
Colour rendering index: 90
Dimmer function: Yes
Weight: Kg 6

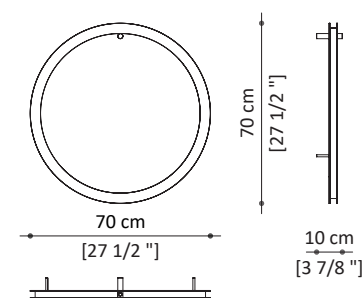
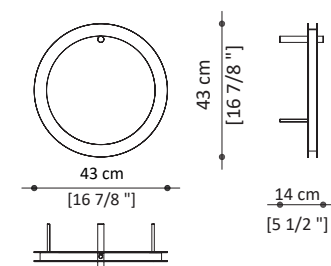
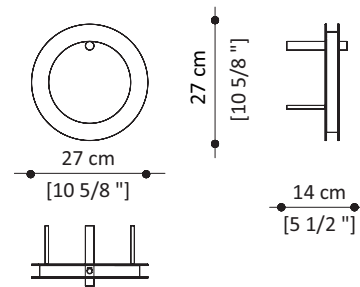

ORIGAMI WALL

Finishes of the above picture



TECHNICAL SHEET
ORIGAMI WALL
Light source: LED
Total power: 6W
Voltage: 24V
Rated Luminous Flux: 600
Colour temperature: 3000°K Color
Rendering Index: Standard CRI 90
Dimmer function: No

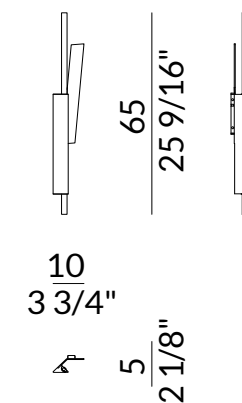

FAIR LIGHT

Finishes of the above picture

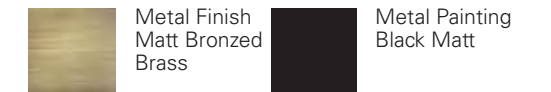

TECHNICAL SHEET
FAIR LIGHT 60
Light source: Strip LED
Total power: 14,4W
Voltage: 24V
Rated luminous flux: 1760 Lm
Colour temperature: 2700° K
Colour rendering index: Ra>80
Dimmer function: No
Weight: Kg 2

TECHNICAL SHEET
FAIR LIGHT 110
Light source: Strip LED
Total power: 28.8W
Voltage: 24V
Rated luminous flux: 1760 Lm
Colour temperature: 2700° K
Colour rendering index: Ra>80
Dimmer function: No
Weight: Kg 3

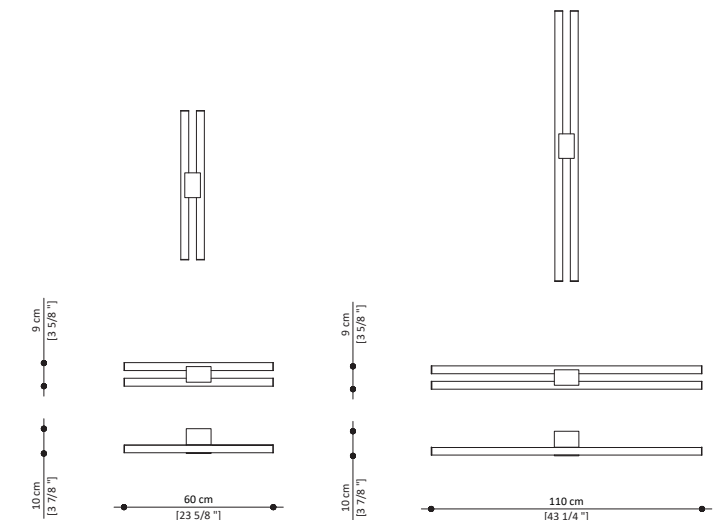

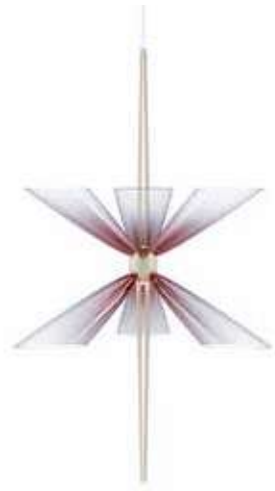

STELLANTIS

Finishes of the above picture



TECHNICAL SHEET STELLANTIS

Light source: LED
 Total power: 32W
 Voltage: 220V
 Rated Luminous Flux: 2180 Lm
 Colour Temperature: 3000°K
 Color Rendering Index: Standard CRI>90
 Suspension cable length: 200 cm
 Dimmer function: Yes
 Weight: 18 kg

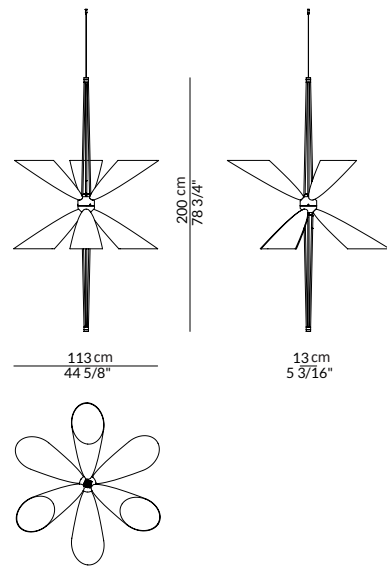

VENUS

Finishes of the above picture



TECHNICAL SHEET VENUS ROUND

Light source: Strip Led 9,6 W/M + 5 led spot x 3W
 Total power: 63W
 Voltage: 230V
 Rated luminous flux: 1880 Lm
 Colour temperature: 3000° K
 Colour rendering index: Ra>80
 Suspension cables length: 200 cm
 Dimmer function: Yes - only for spots
 Weight: Kg 70
 Package size structure: 117x117x40 cm
 Package weight structure: Kg 46
 Package size glass: 117x67x80 cm
 Package weight glass: Kg 116

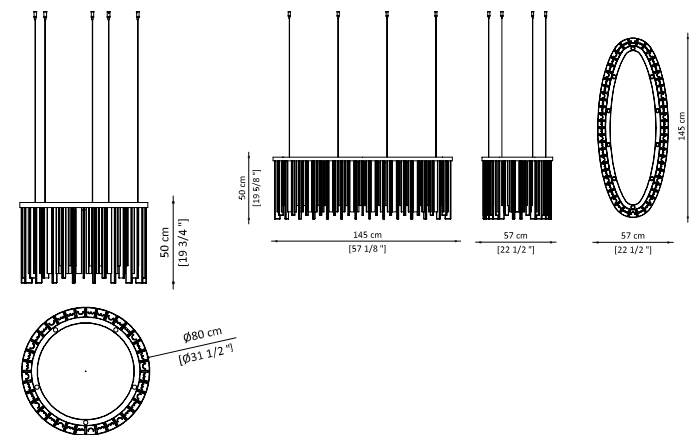

WAVE

Finishes of the above picture



TECHNICAL SHEET WAVE

Light source: LED
 Total power: 117W
 Voltage: 220-240V
 Rated luminous flux: 5000 Lm
 Colour temperature: 3000° K
 Colour rendering index: Ra>85
 Dimmer function: No
 Weight: Kg 52
 Package size: 134x74x63 cm
 Package weight: Kg 109
 Package volume: Kg 0,63

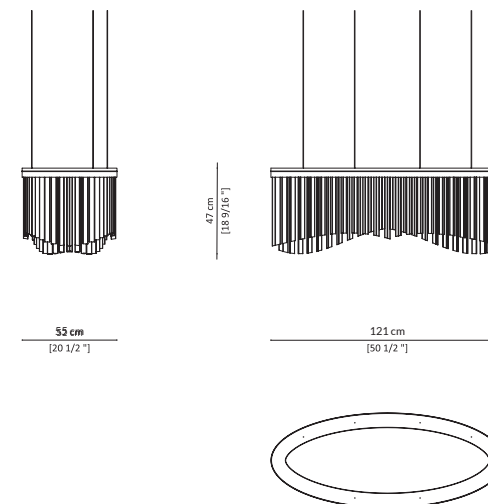

ROULETTE

Finishes of the above picture

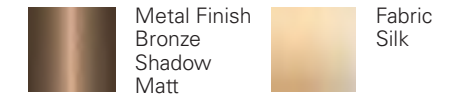

TECHNICAL SHEET ROULETTE 60

Light source: LED 3Wx22
 Total power: 66W
 Voltage: 220-240V
 Rated luminous flux: 612 Lm
 Colour temperature: 2700° K
 Colour rendering index: Ra>80
 Dimmer function: No
 Weight: Kg 10
 Package size: 70x70x50cm
 Package weight: Kg 50
 Package volume: Kg 0,25

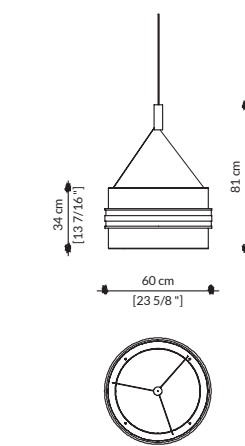

TECHNICAL SHEET ROULETTE 90

Light source: LED 3W x 22
 Total power: 66W
 Voltage: 220-240V
 Rated luminous flux: 612 Lm
 Colour temperature: 2700° K
 Colour rendering index: Ra>80
 Dimmer function: No
 Weight: Kg 26
 Package size: 101x101x54cm
 Package weight: Kg 47
 Package volume: Kg 0,55

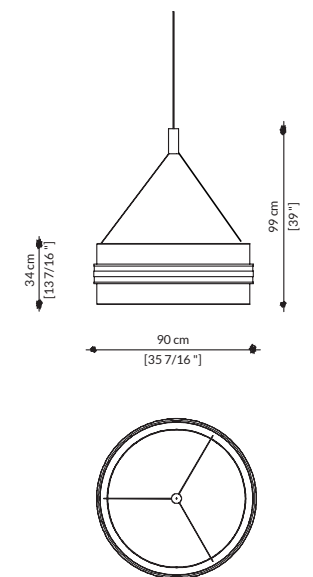



COLETTE & HUGO

Finishes of the above picture



Fabric
Percale



Muranesse glass with
24K golden leaf
powder

TECHNICAL SHEET COLETTE

Light source: E27 light bulb
Lamp socket: E27
Total power: 8W
Voltage: 230V
Rated luminous flux: 1055 lm
Colour temperature: 2700°K
Colour rendering index: Ra>80
Dimmer function: No
Weight: Kg 8
Package size: 55x55x45 cm
(lampshade)
Package size: 40x40x60 cm
(base)
Package weight: Kg 3 (lampshade)
Package weight: Kg 10 (base)

TECHNICAL SHEET HUGO

Light source: E27 light bulb
Lamp socket: E27
Total power: 8W
Voltage: 230V
Rated luminous flux: 1055 lm
Colour temperature: 2700° K
Colour rendering index: Ra>80
Dimmer function: No
Weight: Kg 8
Package size: 55x55x45 cm
(lampshade)
Package size: 50x50x50 cm (base)
Package weight: Kg 3 (lampshade)
Package weight: Kg 10 (base)

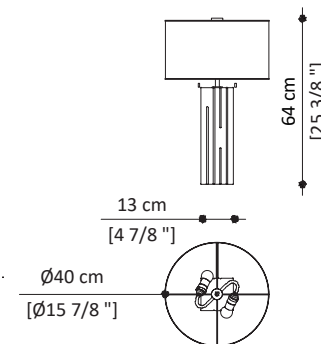
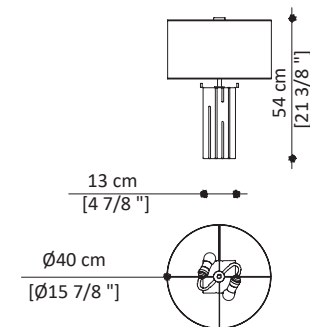
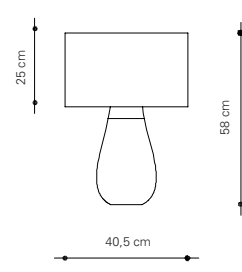
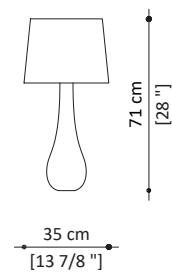

NETTUNO TABLE

Finishes of the above picture



Metal Finish
Matt Gold



Murano
Glass Pink



Fabric
Percale

TECHNICAL SHEET NETTUNO TABLE SMALL

Light source: E27 LED 2X
Total power: 5.5Wx2
Voltage: 220-240V
Rated luminous flux: 470 Lm
Colour temperature: 2700° K
Colour rendering index: Ra>80
Dimmer function: No
Weight: Kg 6
Package size base: 80x28x32 cm
Package weight base: Kg 7
Package volume: Kg 0,07
Package size lampshade:
49x47x45 cm
Package weight lampshade: Kg 2
Package volume: Kg 0,07

TECHNICAL SHEET NETTUNO TABLE BIG

Light source: E27 LED 2X
Total power: 5.5Wx2
Voltage: 220-240V
Rated luminous flux: 470 Lm
Colour temperature: 2700° K
Colour rendering index: Ra>80
Dimmer function: No
Weight: Kg 6
Package size base: 80x28x32 cm
Package weight base: Kg 7
Package volume: Kg 0,07
Package size lampshade:
49x47x45 cm
Package weight lampshade: Kg 2
Package volume: Kg 0,07



AMBRA TABLE

Finishes of the above picture



Metal Finish
Matt
Bronzed
Brass



Fabric
Blended
viscose



Plexyglass
lucite

TECHNICAL SHEET AMBRA TABLE

Light source: E27 light bulb
Lamp socket: 1xE27
Total power: 9W
Voltage: 230V
Rated luminous flux: 1055 lm
Colour temperature: 2700° K
Colour rendering index: Ra>80
Dimmer function: No
Weight: Kg 16
Package size: 52x52x41 cm (lampshade)
Package size: 60x41x40 cm (base)
Package weight: Kg 5 (lampshade)
Package weight: Kg 20 (base)

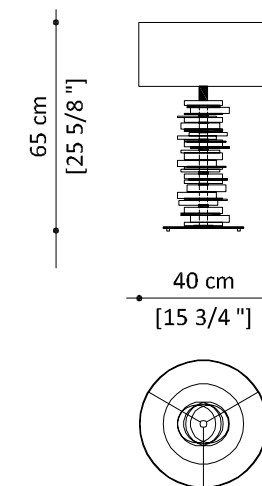



PABLO TABLE

Finishes of the above picture

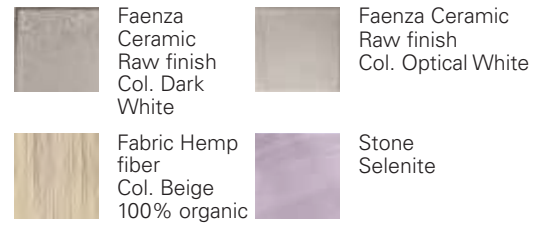

TECHNICAL SHEET PABLO TABLE

Light source: E27 bulb
Total power: 8W
Voltage: 220-240V
Rated luminous flux: 1055 Lm
Colour temperature: 2700° K
Colour rendering index: Ra>80
Dimmer function: No
Weight: 17 Kg

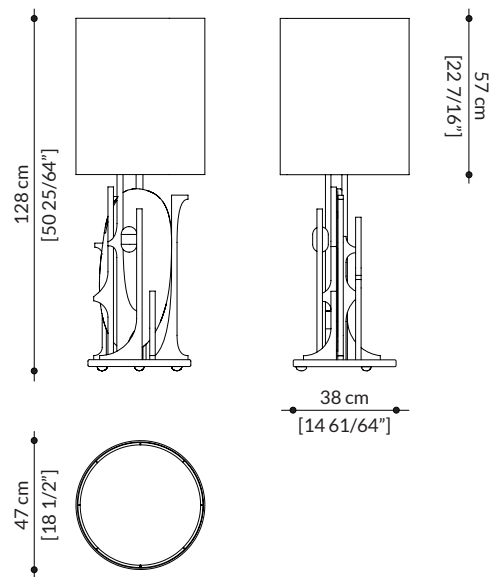

HYPERBOLE TABLE

Finishes of the above picture

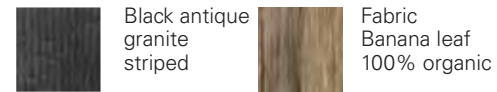

TECHNICAL SHEET HYPERBOLE TABLE

Light source: 2xE27 bulb
Total power: 17W (2x8,5W)
Voltage: 220-240V
Rated luminous flux: 2110 Lm
Colour temperature: 2700° K
Colour rendering index: Ra>80
Dimmer function: no
Weight: 16 Kg

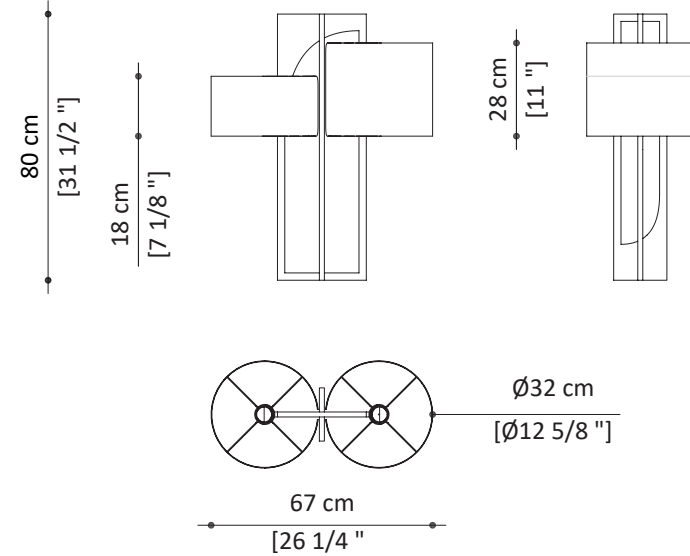

OSCAR TABLE

Finishes of the above picture

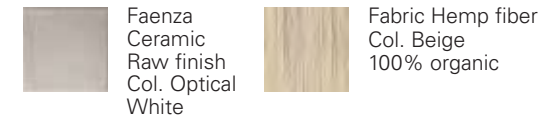

TECHNICAL SHEET OSCAR TABLE

Light source: E27 bulb
Total power: 8W
Voltage: 220-240V
Rated luminous flux: 1055 Lm
Colour temperature: 2700° K
Colour rendering index: Ra>80
Dimmer function: No
Weight: 6 Kg

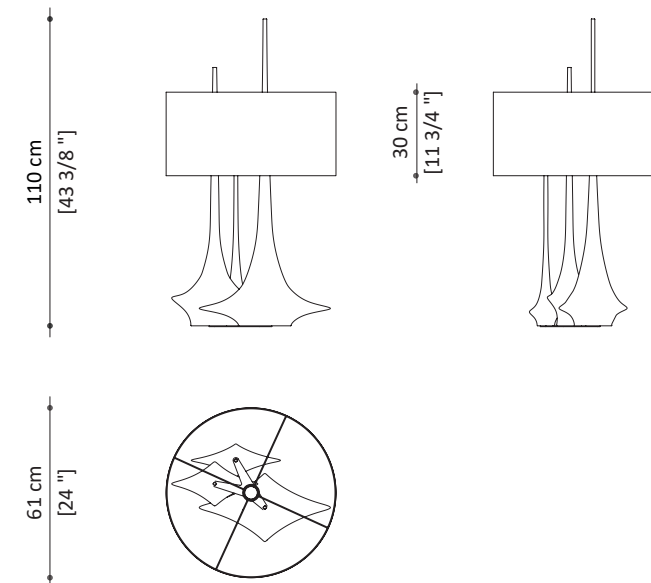

KAALA TABLE

Finishes of the above picture

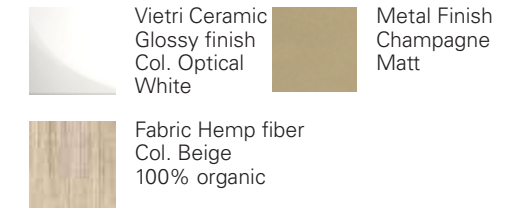

Alternative base option

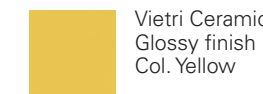

Alternative lampshade option

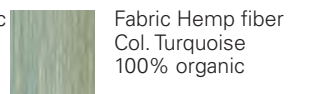

TECHNICAL SHEET KAALA TABLE

Light source: E27 bulb
Total power: 8,5W
Voltage: 220-240V
Rated luminous flux: 1055 Lm
Colour temperature: 2700° K
Colour rendering index: Ra>80
Dimmer function: No
Weight: 6,5 Kg

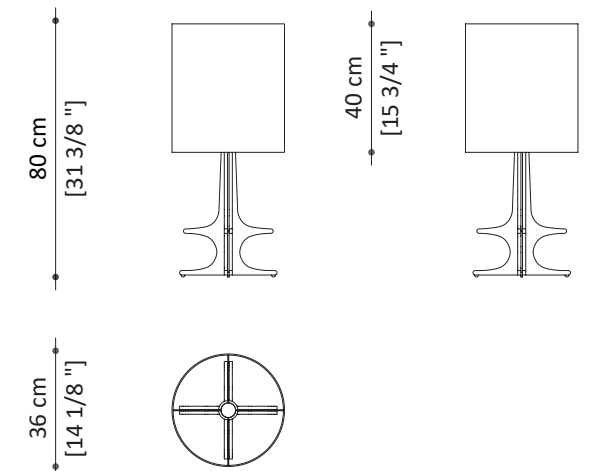



ICONE LUMINOSE

Finishes of the above picture



Metal
Finish
Matt Gold



Amethyst Blue Grey Petrol Green Medium Amber Brown Fumè

TECHNICAL SHEET
LAMP 01 AND 04
Light Source: 3x250mA 2,5W
Total Power: 6,5W
Colour temperature: 3000 K
Power supply: 230V 50/60Hz
Luminous flux: 1000 Lm
Dimmer function: No
Apparatus in CL1

TECHNICAL SHEET
LAMP 02 AND 03
Light Source: 4x250mA 2,5W
Total Power: 8W
Colour temperature: 3000 K
Power supply: 230 V 50/60 Hz
Luminous flux: 1000 Lm
Dimmer function: No
Apparatus in CL1

01

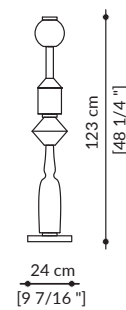

02

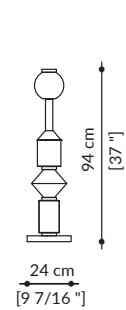

03

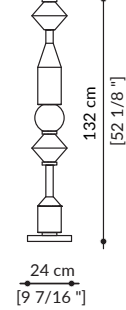

04

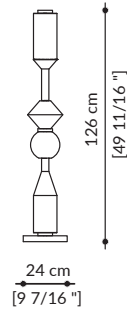

ICONE LUMINOSE TABLE

Finishes of the above picture

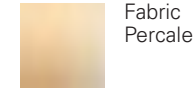

Fabric
Percalè

TECHNICAL SHEET
ICONE LUMINOSE TABLE
Light source: E27 light bulb
Lamp socket: E27
Total power: 8W
Voltage: 230V
Rated luminous flux: 1055 lm
Colour temperature: 2700°K
Colour rendering index: Ra>80
Dimmer function: No
Weight: Kg 8
Package size: 55x55x45 cm (lampshade)
Package size: 40x40x60 cm (base)
Package weight: Kg 3 (lampshade)
Package weight: Kg 10 (base)

MOD 01

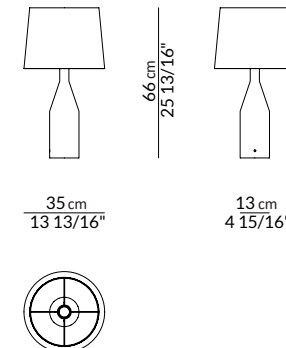

MOD 02

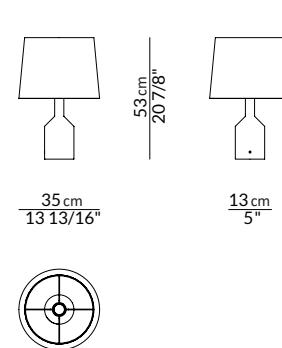



PAOLO CASTELLI

BOLOGNA
Headquarter

MILAN
Showroom

PARIS
Showroom

CARRARA
Marine Division

HEADQUARTER VIA 1° MAGGIO, 93 | 40064 OZZANO DELL'EMILIA | BOLOGNA - ITALY
TEL. +39 051 4695511 | info@paolocastellispa.com | www.paolocastelli.com