

METAMORPHOSIS COLLECTION 2026

ME  
TA  
MOR  
PHO  
SIS

Frigerio

# METAMORPHOSIS

2026 ——— COLLECTION

**Savoir-faire e immaginazione, tradizione e contemporaneità, heritage e sperimentazione:** Frigerio riscopre il fascino della memoria e presenta nuovi progetti che si muovono con disinvoltura tra mondi e periodi storici diversi, in un equilibrio armonico tra razionalità e decorazione. La nuova **collezione 2026** coinvolge i designer **Gordon Guillaumier** e **Calvi Brambilla** nella rilettura dei classici della storia del design attraverso una lente contemporanea, in un dialogo con l'arte.

*Savoir-faire and imagination, tradition and modernity, heritage and experimentation:* Frigerio rediscovers the charm of memory and introduces new projects moving with ease between different worlds and historical periods, in a harmonious balance between rationality and decoration. The new **2026 collection** sees designers **Gordon Guillaumier** and **Calvi Brambilla** reinterpreting design classics through a contemporary lens, in dialogue with the arts.

**Frigerio**

La collezione **Metamorphosis 2026** di Frigerio parla un linguaggio in cui gli oggetti diventano espressione di incontri e continuità, ma anche di cambiamento poetico: un palcoscenico domestico sospeso tra passato e futuro, dove arredi scultorei senza tempo, radicati nell'immaginario collettivo, si aprono a interpretazioni inaspettate e a prospettive contemporanee.

*The Frigerio 2026 Metamorphosis Collection speaks a language where objects become an expression of encounters and continuity, but also of poetic change: a domestic stage suspended between past and future, where timeless sculptural furnishings, rooted in the collective imagination, open up to unexpected interpretations and contemporary perspectives.*



## MODERNIST \_\_\_\_\_ HOME

Lightness, open space and refinement for a quite elegant revelation

Modernist home: spazi aperti, ampie vetrate che sfumano il confine tra interno ed esterno e una gamma di materiali naturali. Un design pensato per migliorare la vita delle persone.

*Modernist home: open floor plans, large windows blurring the boundary between interior and exterior, and a palette of natural materials. Design meant to improve human life.*



## BRUTALIST \_\_\_\_\_ HOME

Honest, concrete and sculptural for a fully authentic design

Brutalist home: audaci e scultorei, edifici che rivelano la realtà dei materiali con cui sono realizzati e sulle tecniche di costruzione. Imponenti, e sorprendentemente accoglienti nella loro essenzialità.

*Brutalist home: bold and sculptural, a building telling the truth about what it is made of and how it is built. Powerful, and surprisingly warm into its rawness.*

**DAO SOFT | SOFA**  
GORDON GUILLAUMIER



PAG. II / 79

**DAVIS SWING | SOFA**  
R&D FRIGERIO



PAG. 37

**DAO SOFT | SMALL TABLE**  
GORDON GUILLAUMIER



PAG. 83

**KUMO | TABLE**  
CALVI BRAMBILLA



PAG. 47 / 93

**FELIX | SOFA**  
CALVI BRAMBILLA



PAG. 87

**DAFNE | ARMCHAIR**  
GORDON GUILLAUMIER



PAG. 23 / 101

**FOSCA | SMALL ARMCHAIR**  
GORDON GUILLAUMIER



PAG. 53 / 96

**VETRA | SIDEBBOARD**  
R&D FRIGERIO



PAG. 61 / 111

**LINDA | ARMCHAIR**  
R&D FRIGERIO



PAG. 41 / 105

**TOM | POUF & SMALL TABLE**  
CALVI BRAMBILLA



PAG. 29

**METIS | BENCH**  
R&D FRIGERIO



PAG. 71 / 109

**ADRIAN, KIMI, THEO & RUBEN | CARPET**  
R&D FRIGERIO



PAG. 117 / 119 / 121 / 123



MODERNIST HOME

Elegante espressione di una discreta raffinatezza che prende forma con un design audace.

*Elegant expression of understated sophistication shaped with daring design.*

/ DAFNE AMRCHAIR  
/ CLARA AMRCHAIR  
/ TOM POUF AND SMALL TABLE  
/ ELLY SERVER  
/ MOCKI SMALL TABLE  
/ VETRA SIDEBOARD  
/ KIMI CARPET

DAO SOFT SOFA / DESIGN BY \_\_\_\_\_ GORDON GUILLAUMIER

# DAO SOFT SOFA

\_\_\_\_\_  
GORDON GUILLAUMIER



/ DAFNE AMRCHAIR  
/ TOM POUF AND SMALL TABLE  
/ ELLY SERVER  
/ MOCKI SMALL TABLE  
/ VETRA SIDEBOARD  
/ KIMI CARPET

DAO SOFT SOFA / DESIGN BY \_\_\_\_\_ GORDON GUILLAUMIER



/ DAFNE AMRCHAIR  
/ TOM POUF AND SMALL TABLE  
/ MOCKI SMALL TABLE  
/ VETRA SIDEBOARD  
/ KIMI CARPET

DAO SOFT SOFA / DESIGN BY \_\_\_\_\_ GORDON GUILLAUMIER



DAO SOFT SOFA / DESIGN BY — GORDON GUILLAUMIER

/ TOM POUF AND SMALL TABLE  
/ ELLY SERVER  
/ KIMI CARPET



DAO SOFT SOFA / DESIGN BY \_\_\_\_\_ GORDON GUILLAUMIER

## METAMORPHOSIS COLLECTION

DAO SOFT SOFA /  
DAO SOFT SMALL TABLE /  
DAFNE ARMCHAIR /  
FOSCA SMALLARMCHAIR /



## GORDON GUILLAUMIER

Gordon Guillaumier, designer maltese, arriva a Milano dopo aver compiuto gli studi in Inghilterra e Svizzera. Nel 2002 apre il proprio studio a Milano, lavorando in ambiti che spaziano dal design del prodotto alla consulenza e design d'interni. Collabora con Frigerio dal 2024 portando il suo segno creativo nella collezione con una forte identità personale.

*Gordon Guillaumier, a Maltese designer, moved to Milan after completing his studies in England and Switzerland. In 2002, he opened his own studio in Milan, working in fields ranging from product design to consultancy and interior design. He has been collaborating with Frigerio since 2024, bringing his creative touch to the collection with a strong personal hallmark.*



# DAFNE

\_\_\_\_\_ GORDON GUILLAUMIER

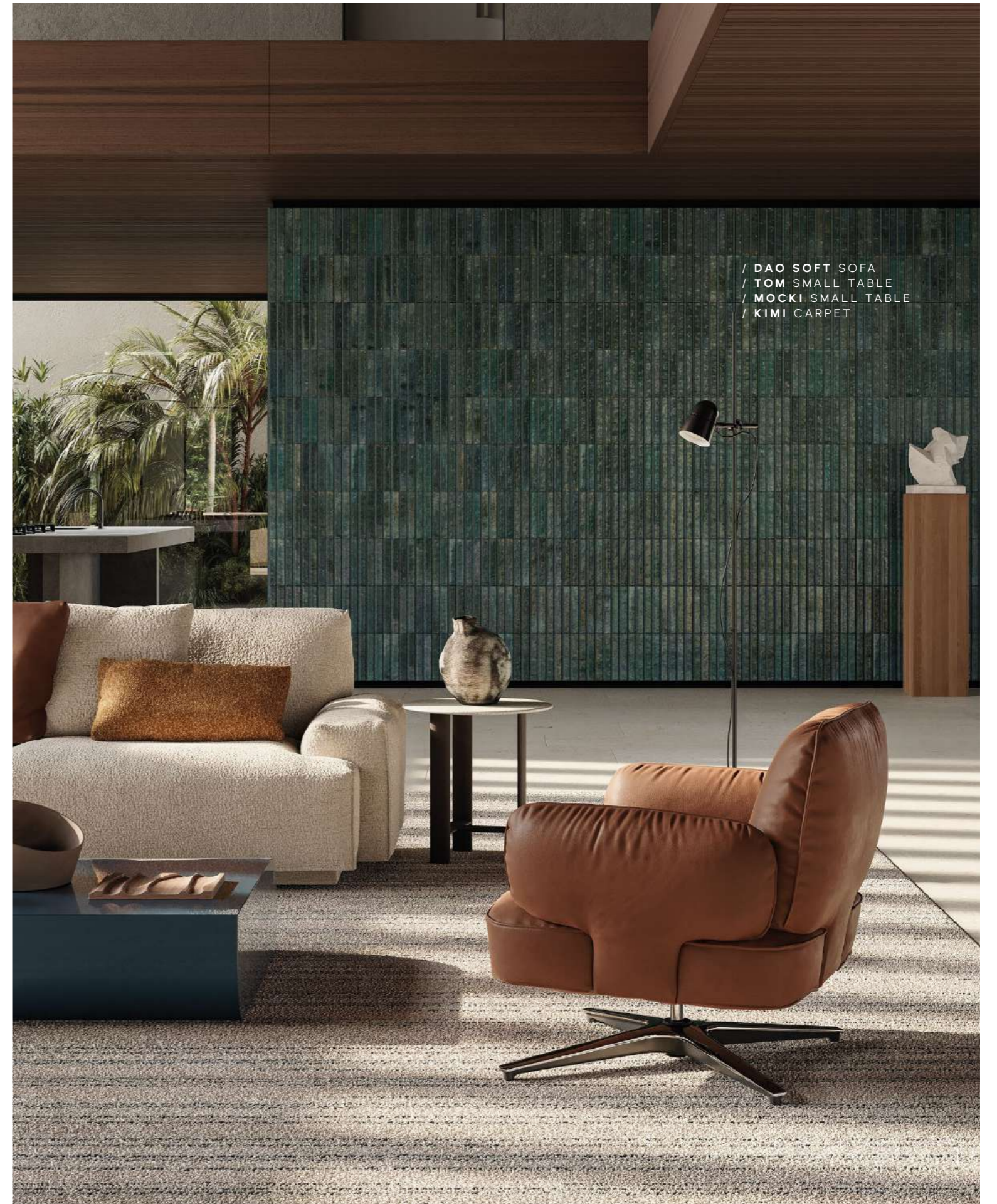

DAFNE ARMCHAIR / DESIGN BY \_\_\_\_\_ GORDON GUILLAUMIER

/ DAO SOFT SOFA  
/ ANDOREA SMALL TABLE  
/ VETRA SIDEBORD  
/ THEO CARPET





DAFNE ARMCHAIR / DESIGN BY ——— GORDON GUILLAUMIER

TOM POUF  
CALVI BRAMBILLA



/ TOM SMALL TABLE  
/ DAO SOFT SOFA  
/ THEO CARPET



TOM POUF / DESIGN BY \_\_\_\_\_ CALVI BRAMBILLA

- / TOM SMALL TABLE
- / DAO SOFT SOFA
- / DAFNE ARMCHAIR
- / MOCKI SMALL TABLE
- / KIMI CARPET



TOM POUF / DESIGN BY \_\_\_\_\_ CALVI BRAMBILLA





/ DAVIS FLAT 74 SOFA  
/ JONAS POUF  
/ SANTAMONICA POUF & SMALL TABLE  
/ ADRIAN CARPET

DAVIS SWING SOFA / DESIGN BY \_\_\_\_\_ R&D FRIGERIO



## DAVIS SWING

R&D FRIGERIO



DAVIS SWING SOFA / DESIGN BY R&D FRIGERIO

# LINDA

R&D FRIGERIO



/ DAVIS SWING SOFA  
/ SANTAMONICA SMALL TABLE & POUF  
/ ADRIAN CARPET

LINDA ARMCHAIR / DESIGN BY \_\_\_\_\_ R&D FRIGERIO

/ JONAS POUF  
/ SANTAMONICA SMALL TABLE  
/ ADRIAN CARPET





LINDA ARMCHAIR / DESIGN BY \_\_\_\_\_ R&D FRIGERIO



/ FOSCA SMALL ARMCHAIR  
/ RUBEN CARPET



# KUMO

\_\_\_\_\_ CALVI BRAMBILLA

KUMO TABLE / DESIGN BY CALVI BRAMBILLA

/ FOSCA SMALL ARMCHAIR  
/ RUBEN CARPET





**KUMO** TABLE / DESIGN BY \_\_\_\_\_ CALVI BRAMBILLA



# FOSCA

\_\_\_\_\_ GORDON GUILLAUMIER



/ KUMO TABLE  
/ RUBEN CARPET

METAMORPHOSIS COLLECTION

FOSCA SMALL ARMCHAIR / DESIGN BY \_\_\_\_\_ GORDON GUILLAUMIER

/ KUMO TABLE  
/ RUBEN CARPET





FOSCA SMALL ARMCHAIR / DESIGN BY \_\_\_\_\_ GORDON GUILLAUMIER





VETRA SIDEBOARD / DESIGN BY R&D FRIGERIO



HUG BAR STOOL  
ELLY TABLE

# VETRA

\_\_\_\_\_ R&D FRIGERIO

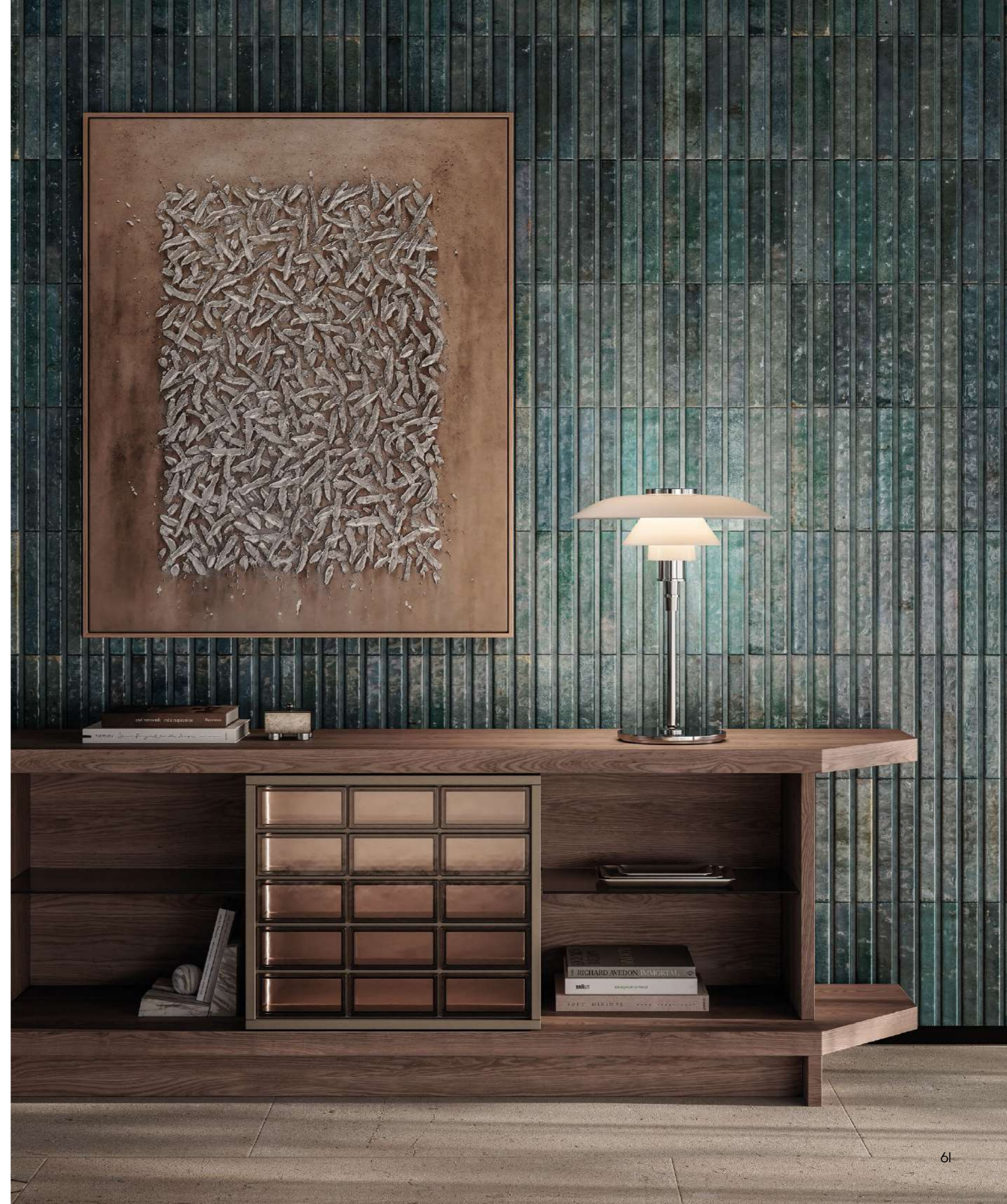



VETRA SIDBOARD / DESIGN BY R&D FRIGERIO





VETRA SIDEBOARD / DESIGN BY \_\_\_\_\_ R&D FRIGERIO



METIS BENCH / DESIGN BY \_\_\_\_\_ R&D FRIGERIO

/ JONAS POUF  
/ ADRIAN CARPET



# METIS

————— R&D FRIGERIO

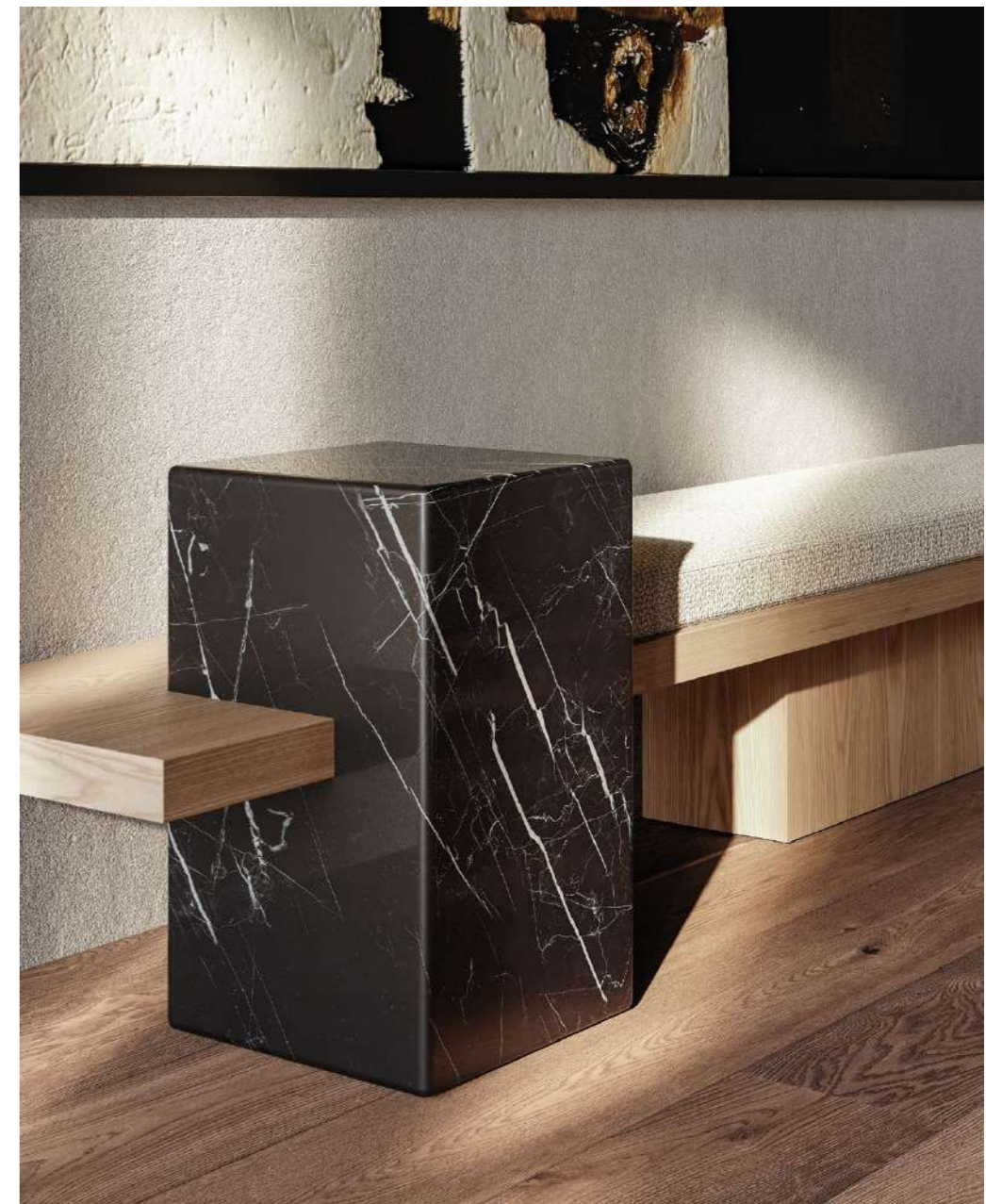



**METIS BENCH** / DESIGN BY \_\_\_\_\_ R&D FRIGERIO

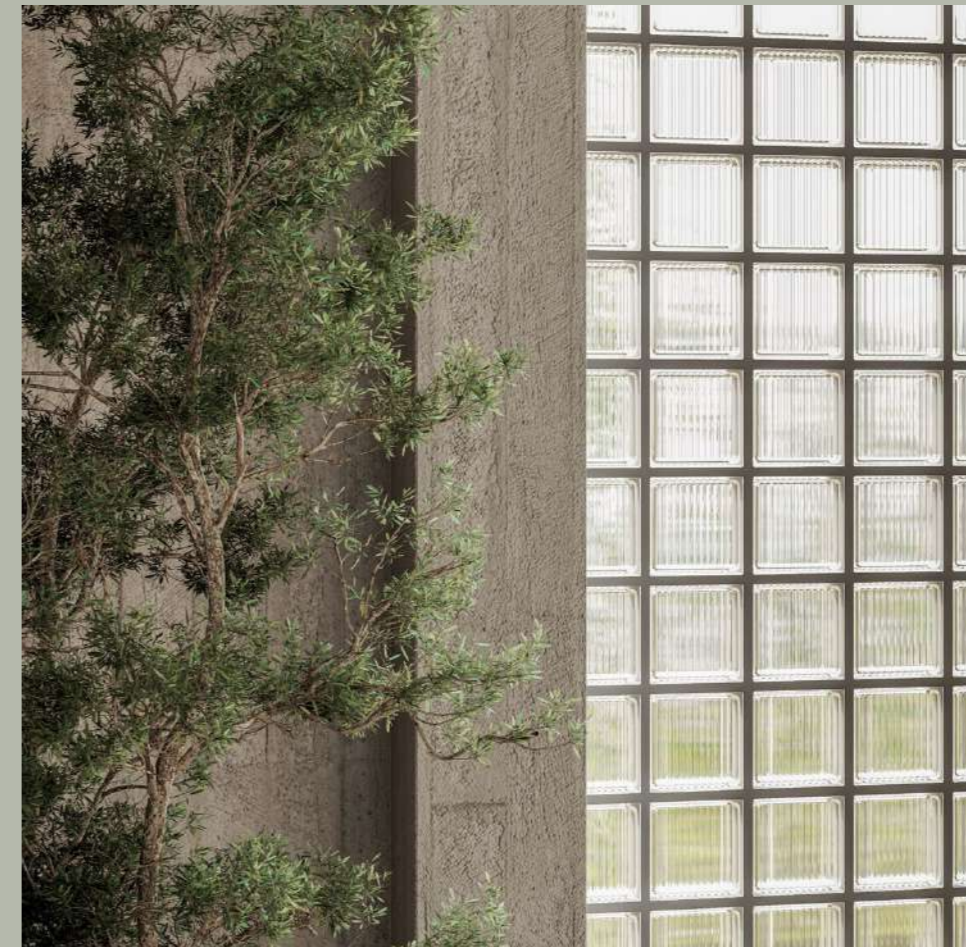

## BRUTALIST HOME

Di grande impatto visivo ma sorprendentemente accogliente, un design deciso e un forte senso della forma.

*Strong in presence yet unexpectedly inviting, design shaped with a strong sense of form.*



DAO SOFT SOFA / DESIGN BY \_\_\_\_\_ GORDON GUILLAUMIER

- / DAFNE ARMCHAIR
- / TOM POUF AND SMALL TABLE
- / PAN DAYBED
- / VETRA SIDEBOARD
- / RUBEN CARPET



# DAO SOFT SOFA

\_\_\_\_\_ GORDON GUILLAUMIER



/ TOM POUF AND SMALL TABLE  
/ RUBEN CARPET



DAO SOFT SOFA / DESIGN BY ——— GORDON GUILLAUMIER

DAO SOFT SMALL TABLE  
————— GORDON GUILLAUMIER

/ DAO SOFT SOFA  
/ KIMI CARPET





DAO SOFT SOFA, SOFA AND SMALL TABLE / DESIGN BY GORDON GUILLAUMIER

/ DAFNE ARMCHAIR  
/ KIMI CARPET

/ CLARA ARMCHAIR  
/ SAM SMALL TABLE & SERVER  
/ TOM SMALL TABLE  
/ ADRIAN CARPET



# FELIX

CALVI BRAMBILLA

FELIX SOFA / DESIGN BY \_\_\_\_\_ CALVI BRAMBILLA

/ CLARA ARMCHAIR  
/ SAM SMALL TABLE & SERVER  
/ TOM SMALL TABLE  
/ ADRIAN CARPET

## METAMORPHOSIS COLLECTION

KUMO TABLE /  
FELIX SOFA /  
TOM POUF & SMALL TABLE /



## CALVI BRAMBILLA

Fabio Calvi si è laureato in Architettura nel 1996 dopo aver studiato al Politecnico di Milano e alla Brunel University. Paolo Brambilla si è laureato in Architettura nel 1999 dopo aver studiato al Politecnico di Milano e a Barcellona. Dal 2006 collaborano nel campo degli interni, dell'arredamento e del design, coniugando ironia e funzionalità. Hanno iniziato a lavorare con Frigerio nel 2025 portando nella collezione la loro capacità di fondere immaginazione e rigore, elementi d'arredo e soluzioni decorative.

*Fabio Calvi graduated in Architecture in 1996 after studying at Milan Polytechnic and Brunel University. Paolo Brambilla graduated in Architecture in 1999 after studying at Politecnico di Milano and Barcelona. Since 2006, they have been collaborating on interiors, fittings and design, combining irony and functionality. They began working with Frigerio in 2025, bringing to the collection their capabilities of blending imagination and rigor, furniture elements and decorative solutions.*



/ FOSCA SMALL ARMCHAIR  
/ THEO CARPET



# KUMO

————— CALVI BRAMBILLA

KUMO TABLE / DESIGN BY CALVI BRAMBILLA

/ FOSCA SMALL ARMCHAIR  
/ AMY BOOKCASE  
/ THEO CARPET



# FOSCA

\_\_\_\_\_ GORDON GUILLAUMIER



/ KUMO TABLE  
/ AMY BOOKCASE  
/ THEO CARPET



FOSCA SMALL ARMCHAIR / DESIGN BY ——— GORDON GUILLAUMIER

# DAFNE

GORDON GUILLAUMIER

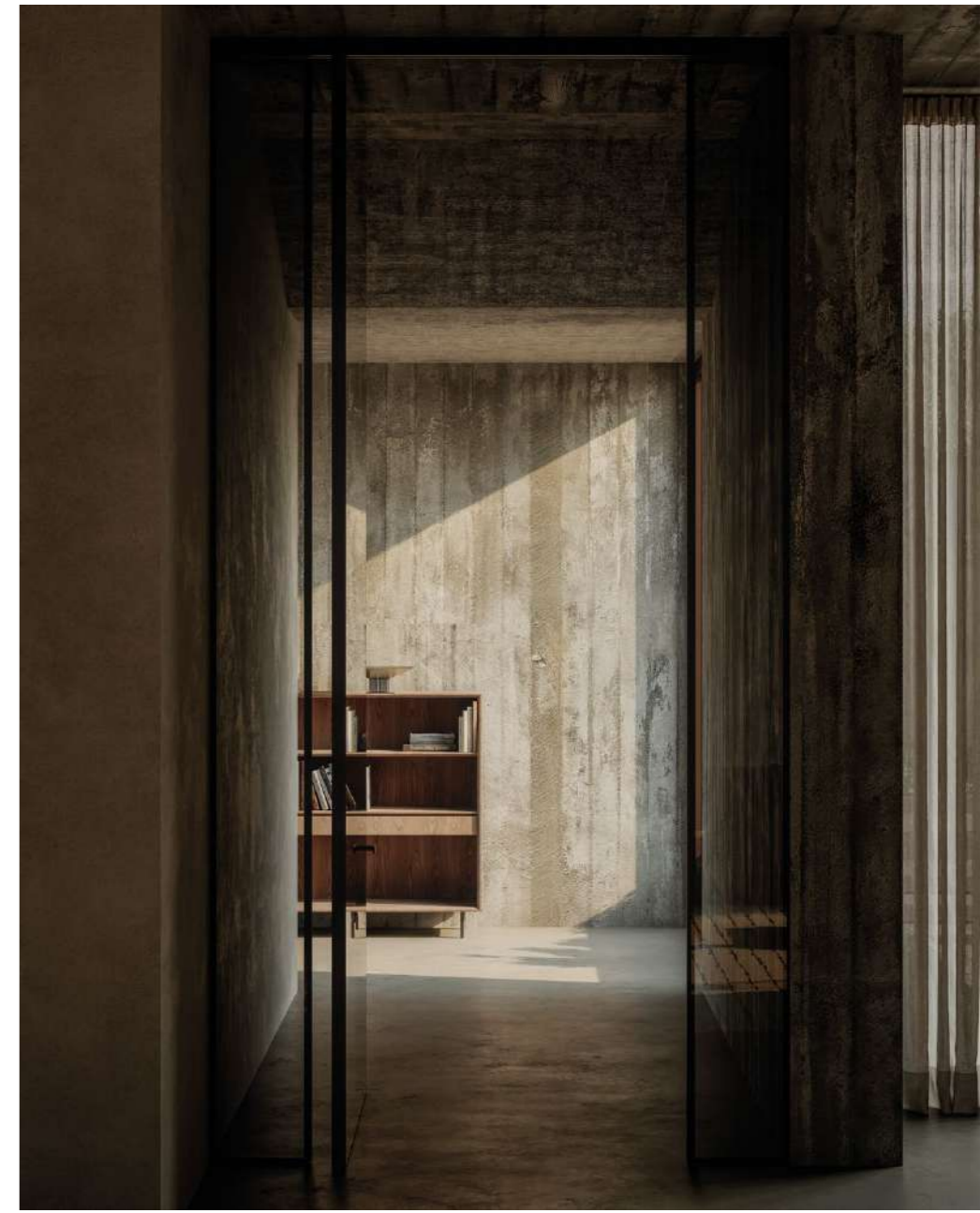



DAFNE ARMCHAIR / DESIGN BY — GORDON GUILLAUMIER

/ TOM POUF AND SMALL TABLE  
/ RUBEN CARPET

/ MOCKI SMALL TABLE  
/ TAMU MIRROR  
/ THEO CARPET



# LINDA

————— R&D FRIGERIO



LINDA ARMCHAIR / DESIGN BY ——— R&D FRIGERIO





# METIS

————— R&D FRIGERIO

# VETRA

\_\_\_\_\_ R&D FRIGERIO



/ PAN ARMCHAIR  
/ RUBEN CARPET



VETRA SIDEBOARD / DESIGN BY ——— R&D FRIGERIO

TECHNICAL DATA \_\_\_\_\_



Il tappeto Theo definisce il suo ritmo attraverso una superficie con fasce incorniciate da frange che cadono come dettagli decorativi. Tonalità naturali su tutta la superficie grazie alla diversa texture.

*Theo carpet defines its rhythm by a surface with bands framed by fringes that fall like decorative details. Natural hues across the surface thanks to the different texture.*

# THEO

R&D FRIGERIO

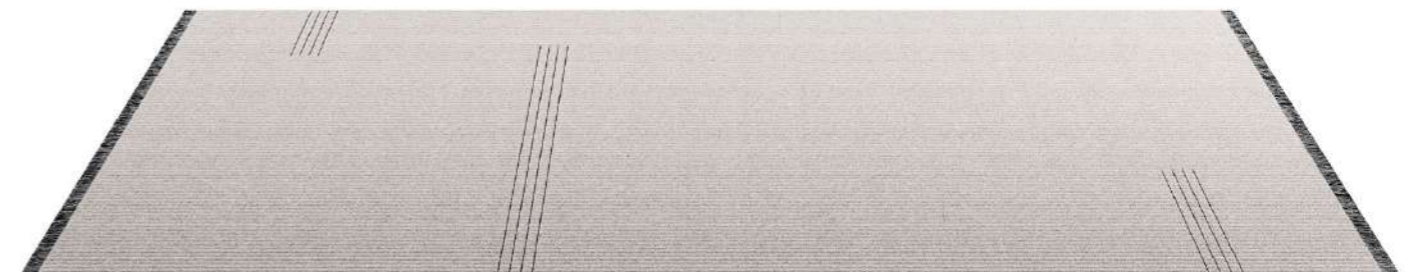
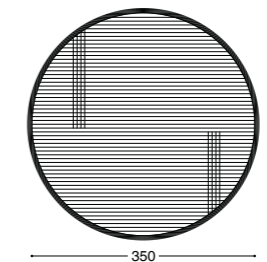
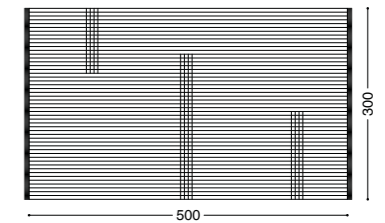
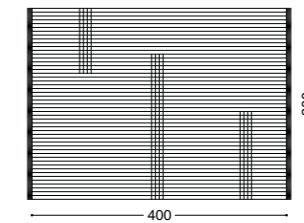
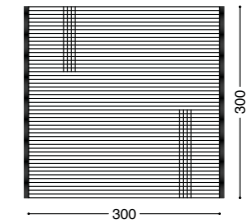
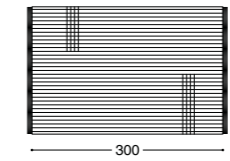



Il tappeto Adrian presenta un colore pieno e intenso con un'unica ampia fascia a contrasto che attraversa la superficie, rendendone l'aspetto più deciso.

*Adrian carpet featuring a full deep colour with a single wide contrasting band across its surface by defining a sharper look.*

# ADRIAN

R&D FRIGERIO

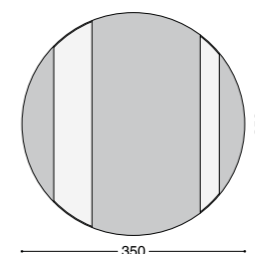
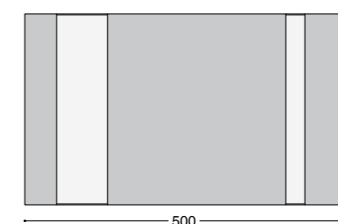
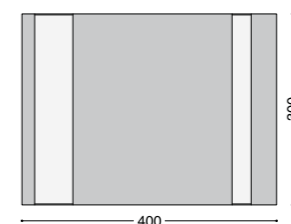
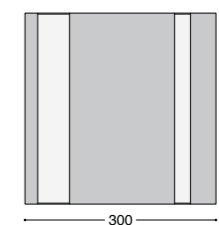
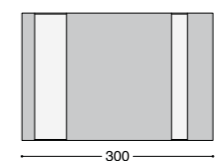

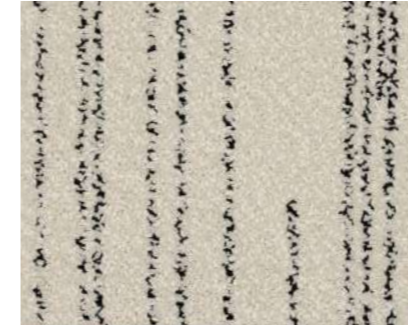

Il tappeto Kimi presenta una base beige naturale con strisce scure e irregolari che si snodano sulla sua superficie come una vera e propria trama del terreno.

*Kimi carpet carries a beige ground natural colour with dark, irregular stripes that wander on its surface like a true grounded texture.*

# KIMI

R&D FRIGERIO

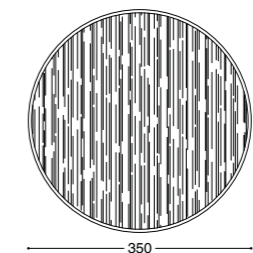
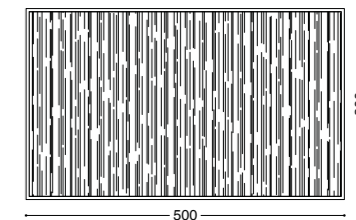
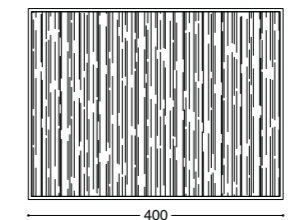
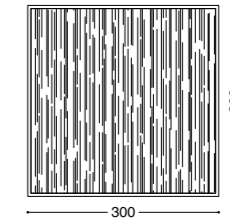
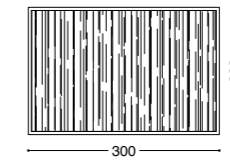



Il tappeto Ruben diventa un classico reinterpretato in un unico colore che rimane costante, mentre il pelo cambia e i passaggi più alti e più bassi catturano la luce scolpendone il disegno.

*Ruben carpet becomes a classic reinterpreted of one colour which stays in constant, while the pile changes and the higher and lower passage catches light by sculpting its pattern.*

# RUBEN

R&D FRIGERIO

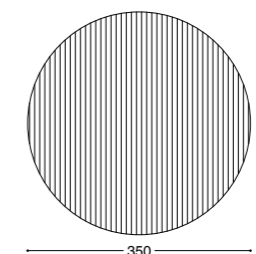
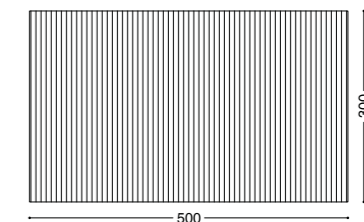
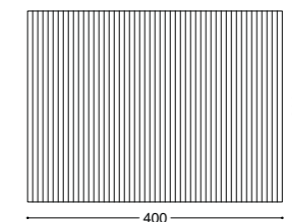
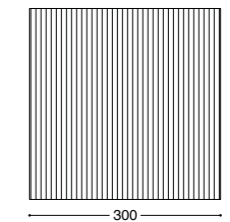
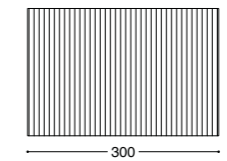



Collezione di divani ed elementi componibili in poliuretano espanso in densità variabile e in Cloud Foam con trapuntino in microflock. Disponibile con basamento rivestito in tessuto o pelle o con piedini. La collezione si completa da tavolini integrati o libero posizionamento nei colori laccati.

Collection of sofas and modular elements in polyurethane foam in different density and Cloud Foam with microflock quilt. Available with base covered in fabric or leather or with feet. The collection is completed by integrated or free standing glossy lacquered small tables.

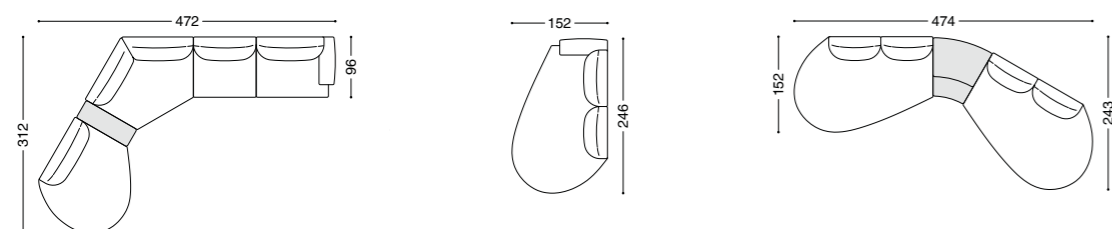

9



24



77



Davis è un sistema di elementi modulari con scelta fra 5 tipi di piedini, 3 tipi di comfort sedute e differenti braccioli. Nuovo bracciolo imbottito Swing con movimento.

Davis is a system of modular elements with choice between 5 different kind of feet. 3 different comfort seat and many armrests. New padded armrest Swing with movement.

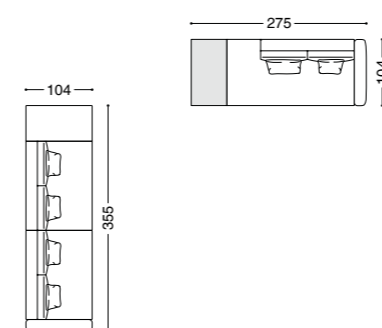

35



40

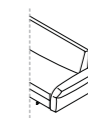
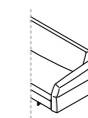
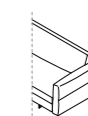



Collezione di divani ed elementi componibili in poliuretano espanso in densità variabile e in memory foam con trapuntino in microflock. Si caratterizza da un tubolare in metallo laccato con intreccio in cuoio che incornicia la parte esterna dei braccioli e dello schienale. La collezione si completa da tavolini integrati nei colori laccati.

Collection of sofas and modular elements in polyurethane foam in different density and memory foam with a microflock quilt. It features a lacquered metallic tubular with hide leather weave enriching the external part of the armrests and backrest. The collection is completed by integrated small tables in lacquered colours.

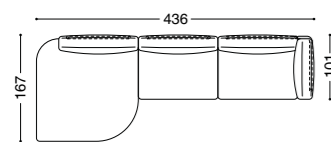

SAND SABLÉ  
HIDE LEATHER 30



TITANIUM  
HIDE LEATHER 28



BURGUNDY SABLÉ  
HIDE LEATHER 3



89



Poltrona girevole rivestita in tessuto o pelle con base a razze in alluminio.

Swivelling armchair covered in fabric or leather with star-shaped aluminium base.

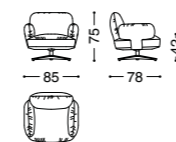

23



100



103



Poltrona con struttura in legno curvato con materassina imbottita in poliuretano rivestita in tessuto o pelle. Disponibile nella versione con o senza braccioli.

Armchair with curved wood with padded cushion in polyurethane covered in fabric or leather. Available in the version with or without armrests.

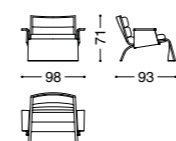
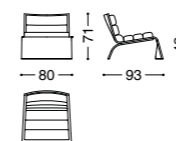

40



43



104



Tavolo da pranzo in varie dimensioni con top e gambe in marmo.

Dining table in different sizes with top and legs in marble.

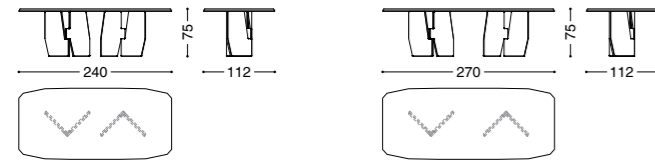

47



92



Collezione di pouf in diverse dimensioni disponibili in tessuto o pelle.

Collection of pouf in different dimensions available in fabric or leather.

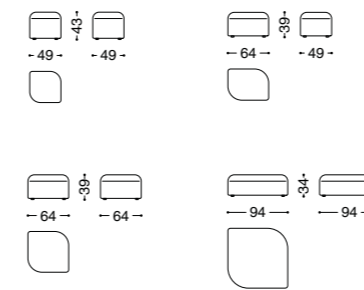

29



77



Poltroncina con 3 punti di appoggio. Schienale e seduta imbottiti e rivestiti in tessuto o pelle e struttura in legno o colori laccati.

Small armchair with 3 supporting legs. Back and seat padded covered in fabric or leather and structure in wood or lacquered colours.

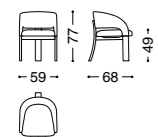

53



97



Collezione di tavolini coordinati al divano o libero posizionamento di differenti dimensioni nei colori laccati lucidi.

Collection of small tables coordinante with the sofa or freestanding in different sizes in glossy lacquered colours.

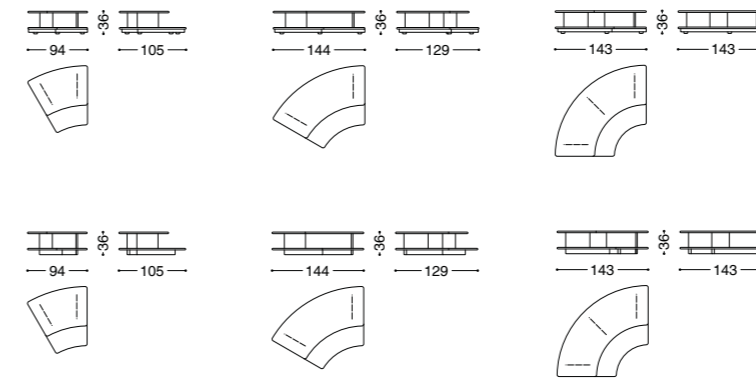

83



Mobile contenitore con angoli smussati con struttura in frassino nei colori della collezione, ante a scorrimento con telaio metallico e blocchi di vetrocemento rettangolari color bronzo decorativi.

Sideboard with rounded edges with ashwood structure in the colours of the collection, with sliding doors with metal frame and decorative rectangular bronzed-coloured glass-block elements.

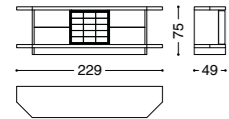

59



62



Panca con seduta in frassino e materassina in poliuretano rivestita in tessuto o pelle supportata da un lato da un volume in marmo ad incastro nelle varianti: Travertino, Rosso Levanto, Verde Levanto, Nero Marquina e Dark Emperador.

Bench with ashwood seat with padded cushion in polyurethane covered in fabric or leather supported by one side by a marble volume in the following finishes: Travertino, Rosso Levanto, Verde Levanto, Nero Marquina and Dark Emperador.

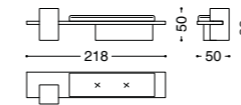

69



70



Mobile contenitore con angoli smussati con struttura in frassino nei colori della collezione, ante a scorrimento con telaio metallico e blocchi di vetrocemento rettangolari color bronzo decorativi.

Sideboard with rounded edges with ashwood structure in the colours of the collection, with sliding doors with metal frame and decorative rectangular bronzed-coloured glass-block elements.

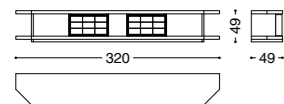

25



III



108

**Art Direction:**

R+W

**Graphic Project:**

Michela Boglietti

**Project Coordination:**

R&D Frigerio

**Images Creation:**

Art Direction / Stylist: Francesca Fani Studio

Digital Modeling: Stefano Benfatto

**Photo:**

Designer: Federico Cimaz

Still-life: Studio Eleven

**Colour Separation:**

CD cromo

# Frigerio

FRIGERIO POLTRONE E DIVANI SRL

Via Sant'Agata, 63

Mariano Comense CO - Italy

T. +39 031 5481225

[www.frigerio.com](http://www.frigerio.com)

